

Daylighting

Prescription for
Affordable Housing In India

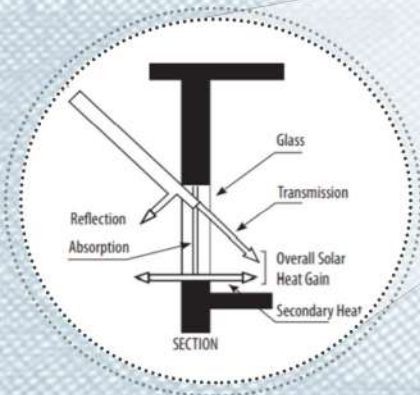
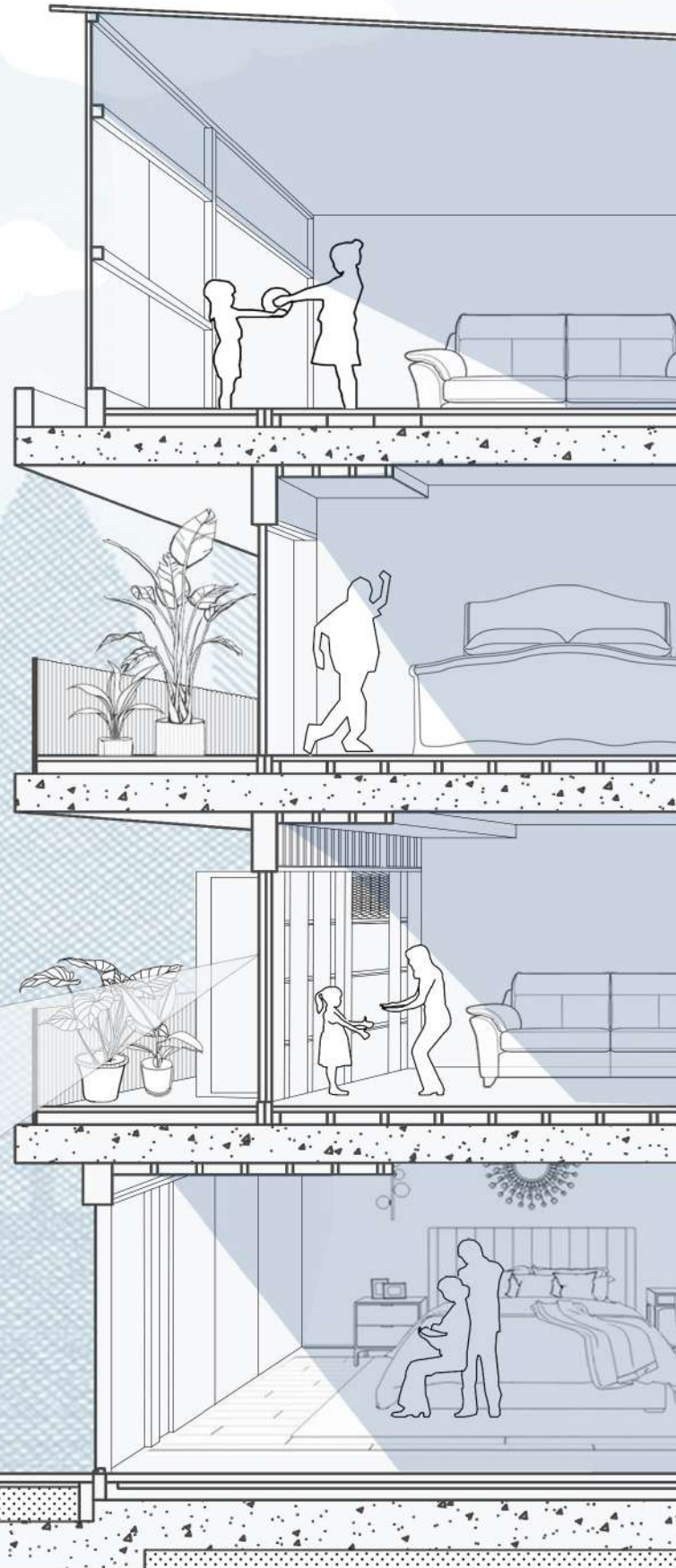

© The Energy and Resources Institute 2021

Suggested format for citation

TERI. 2021
Daylighting Prescription for Affordable Housing in India
New Delhi: The Energy and Resources Institute. 566 pp.
[Project Report No. 2016BS02]

The Team

Authors

Ms Riya Malhotra, Project Associate, TERI

Ms Megha Behal, Consultant, TERI

Technical Team

Mr Sanjay Seth, Senior Director, TERI

Dr Priyam Tewari, Associate Fellow, TERI

Dr Rana Veer Pratap Singh, Research Associate, TERI

Ms Riya Malhotra, Project Associate, TERI

Ms Megha Behal, Consultant, TERI

Technical Reviewer

Prof. Ashok B. Lall, Principal Architect, A.B. Lall Architects

Dr Sunita Purushottam, Head of Sustainability, MLDL

Support Team

Mr Dharmender Kumar, Administrative Officer, TERI

Editorial and Design

Ms Muskaan Johri, Raman Kumar Jha, Vijay Nipane

For more information

Project Monitoring Cell

TERI

Darbari Seth Block

IHC Complex, Lodhi Road

New Delhi – 110 003

India

Tel. 2468 2100 or 2468 2111

E-mail pmc@teri.res.in

Fax 2468 2144 or 2468 2145

Web www.teri.in.org

India +91 • Delhi (0)11

Foreword



The Housing for All mission by 2022 of the Government of India seeks to achieve the Sustainable Development Goals Target 11.1 “By 2030, ensure access for all to adequate, safe and affordable housing and basic services and upgrade slums”. The overall residential construction demand is expected to increase more than fourfold over 2005 levels as a result of meeting the urban housing shortage.

Mahindra Lifespaces and TERI through the Centre of Excellence jointly envisaged to build a greener urban future by developing energy-efficient solutions tailored to Indian climates. The project intends to provide credible information related to thermal properties of building materials in public domain. Under the five-year research scope, the CoE has created guidelines, toolkits, and handbooks to mainstream principles of energy-efficiency, thermal & visual comfort, and sustainable water use in habitat.

Furthermore, the lab established for testing of building material’s thermal properties is a SVAGRIHA 5-star rated facility that leads by example to achieve net-zero energy goals. The Centre is accredited by National Accreditation Board for Testing & Calibration Laboratories for thermal testing of building materials. The CoE has generated interest amongst government institutions, academia, and industry, globally. It is successfully established as a frontrunner in the materials market for testing instilling confidence in our research community. The publication focuses on aspects related to daylighting and thermal comfort in affordable housing. Both issues are disregarded during design stages often leading to energy-intensive and uncomfortable indoor spaces. The reports specify quick rules and prescriptive requirements to aid designers make informed design decisions. It details out design processes and strategies to integrate daylighting and enhance thermal comfort in residential buildings.

We suggest reading the Part – 1 ‘Daylighting’: Prescription for affordable housing in India and Part – 2 ‘Thermal Comfort’: Prescription for cooling-dominated Indian residential buildings in conjunction as both issues cannot be addressed in isolation. However, it was essential to create two stand-alone parts distinctly explaining the fundamentals of daylighting and thermal comfort.

We hope that the designers and students find the reports of relevance and apply the principles in the buildings they create tomorrow.

Sanjay Seth
Senior Director
Sustainable Habitat Programme, TERI

Table of Contents

Introduction	1
Daylighting: Definitions, Classification and Context	5
Definitions in Literature	5
What do we understand by it?.....	5
Classification of daylighting system based on daylight admittance in a building	6
Daylighting System in the Indian Context	7
Classification of daylight system based on affordable housing in India.....	8
Parameters: Daylight Availability, Transmission and Calculations	11
Latitude	11
Building Orientation, Shape, and Massing.....	12
Sky type.....	13
Clear sky.....	14
Intermediate sky	14
Overcast sky	14
Fenestration – Size.....	14
Fenestration – Glass	15
Shading	19
Building: Obstructions and surface reflectance	21
Building: Envelope	22
Daylight Performance Metrics	25
Daylight Factor.....	25
Daylight Autonomy.....	26
Continuous and Spatial Daylight Autonomy.....	26
Useful Daylight illuminance and Climate-based daylight modelling	27
Annual Sunlight Exposure	28
Daylighting: Tips and Thumb Rules	31
Day-lit area for massing studies	31
Window head height: The rule of 2.5.....	31
Atrium rule of thumb.....	32
The 15/30 rule of thumb	32
Window design tips.....	33
Height of windows.....	33
Placement of windows.....	33
Shading: Thumb rules	34
Fenestration Design	37
Conclusion	41
Annexure 1	43
Annexure 2	47
Annexure 3	49
References	53

List of Tables

Table 1:	daylight system applicable to affordable housing in India (based on literature study).....	9
Table 2:	Minimum requirement of window-to-floor area ratio for residential buildings in India [21]	15
Table 3:	Suggested properties: Energy performance for single glass [22].....	16
Table 4:	Non-energy properties of a glass [22]	16
Table 5:	Properties of fenestration-glass system [18].....	17
Table 6:	Minimum requirement of VLT to desired WWR% for residential buildings in India [21].....	18
Table 7:	Diffuse transmittance of glazing [18].....	19
Table 8:	Solar Heat Gain Coefficient (SHGC) for various EMSYS typologies. [22]	21
Table 9:	Surface reflectance range as per Standard Codes and Rating Systems.....	22
Table 10:	Residential Envelope Transmittance Value (RETV) formula [21]	23
Table 11:	Recommended value for illumination and daylight factor for residential space [18].....	26
Table 12:	Daylight performance assessment benchmarks for residential buildings by various green rating system in India.....	29
Table 13:	External shading factor for overhang for Latitude $\geq 23.5^\circ\text{N}$	43
Table 14:	External shading factor for overhang for Latitude $< 23.5^\circ\text{N}$	43
Table 15:	External shading factor for side fin-right for Latitude $\geq 23.5^\circ\text{N}$	44
Table 16:	External shading factor for side fin-right for Latitude $< 23.5^\circ\text{N}$	44
Table 17:	External shading factor for side fin-left for Latitude $\geq 23.5^\circ\text{N}$	45
Table 18:	External shading factor for side fin-left for Latitude $< 23.5^\circ\text{N}$	45
Table 19:	Coefficients (a, b, and c) for RETV formula for cooling dominated climatic zones [21]	46
Table 20:	Orientation factor (ω) for different orientations [21].....	46
Table 21:	Spacing distances between vertical or horizontal members of louver systems (Northern region)	47
Table 22:	Spacing distances between vertical or horizontal members of louver systems (Southern region).....	48

List of Figures

Figure 1:	Why focus on 'daylight systems' for affordable housing in India? [5] [4] [2]	2
Figure 2:	Objectives of applying daylighting systems	3
Figure 3:	Objectives of applying daylighting systems	5
Figure 4:	Classification of daylighting systems based on daylight admittance (Adapted & modified from ECBCS Daylight in Buildings Report) [9]	6
Figure 5:	Climatic zones of India and hierarchy of shading systems	7
Figure 6:	Daylight system in India	8
Figure 7:	(L) Revolution of earth around the sun creating summer and winter solstice(R) Sun angles during summer and winter solstice.....	11
Figure 8:	East-west longer axis/north-south larger facade [18]	12
Figure 9:	Massing studies for daylight area (Adapted from MIT open course work – Sustainable Building Design) [6]	12
Figure 10:	CIE sky model distribution [19]	13
Figure 11:	Variation in window-to-wall ratios [20].....	14
Figure 12:	Fenestration glass – affordable housing classification [22].....	16
Figure 13:	Main shading typologies [18].....	19
Figure 14:	(Right) Projection factor for overhangs and (Left) side fins (Modified from ECBC-R 2018) [21]	20
Figure 15:	Sky angle [6]	21
Figure 16:	Surface Reflectance [6]	22
Figure 17:	Daylight factor illuminance [22].....	25
Figure 18:	Calculation of minimum daylight autonomy for different latitudes, a daylight factor of 2%, and an illuminance threshold of 100 lux [28]	27
Figure 19:	Daylit area for massing studies for different shapes of floor plan having similar floor area considering lintel level at 7 feet [6].....	31
Figure 20:	Daylight Area Calculation for vertical fenestration (section) [11]	31
Figure 21:	Daylight evaluation thumb rule for rectangular or square windows [11].....	32
Figure 22:	Atrium rule of thumb [6].....	32
Figure 23:	Tall versus broad windows [18].....	33
Figure 24:	Opposite side windows give greater uniformity of daylight and improves ventilation [18] ..	33
Figure 25:	Placement of work areas [10].....	34

Figure 26:	Strip versus punched windows [18]	34
Figure 27:	Placement of shading devices as per facade’s direction for external shading. [23].....	35
Figure 28:	Placement of trees as per facade’s direction for external shading (modified and adapted from NBC-2016) [16]	35
Figure 29:	(L) Window plan--one vertical louver (normal/inclined) louver for the whole window, (R) Window split into two-louver lengths also’ get halved-one louver for each half. [8]	35
Figure 30:	Overhang divided into multiple overhangs [16]	
Figure 31:	Using sun path for showing compliance for surrounding obstructions [11].....	36
Figure 32:	Stages of the building envelope design [9]	37
Figure 33:	Fenestration design methodology [31] [21] [32] [18] [33].....	38
Figure 34:	Window angle in a shading device [18].....	39
Figure 35:	Dimensions of one block and distance between two blocks by applying atrium thumb rule	49
Figure 36:	Cluster of four-dwelling units.....	49
Figure 37:	Case-1 South elevation with 2m wide windows	50
Figure 38:	Plan A designed from the base case	51
Figure 39:	Plan B option.....	51
Figure 40:	Case-2 South elevation with 1m wide each.....	52
Figure 41:	Comparison between case-1 windows and case-2 windows	52

Introduction

The population of India has grown to 1.38 billion in 2020, with an increase of 180 million in the previous decade [1]. It has fostered rapid urbanization in the country. About 377 million Indians comprising 31.14% of the population lived in urban areas in 2011. [2] The urban population is projected to grow at a rate of 2.38% to about 600 million (40%) by 2031 and 850 million (50%) by 2051 [3]. The urban shift brings challenges including meeting accelerated demand for basic services, infrastructure, jobs, land, and housing particularly for the urban poor. Rapid urbanization has led to an increase in the housing problem, overcrowding in small houses with the steady growth of slums and unplanned settlements, and severe deleterious effects on civic services in urban areas. Thus, the influx in the urban demographics has escalated the demand for urban infrastructure.

The repercussion of the growing concentration of people in urban areas is felt in land and housing shortages and congested transit, besides the stress on basic amenities such as water, power, and living spaces. The Ministry of Housing and Urban Development estimated a housing shortage of 18.78 million during the 12th Plan period, with 96% lying in the economically weaker and lower income groups. In 2001, the total number of households in urban areas was 53.7 million which increased to 78.9 million in a decade. [4] In this context, several policies were introduced by the government including National Urban Housing & Habitat Policy (NUHHP2007), the Jawaharlal Nehru National Urban Renewal Mission (JNNURM-2005), Basic Services for the Urban Poor (BSUP), Integrated Housing & Slum Development Programme (IHSDP), the Rajiv Awas Yojana (2011) along with its second component – Affordable Housing in Partnership (AHP2015), and the most recent being the Pradhan Mantri Awas Yojna (2015) with a goal of ‘Housing for all’ by 2022.

The expectations for achieving better domestic comforts with the growth of residential demand and floor space leads to an increase in household electricity consumption which in turn requires an increase in electricity production. Out of the total electricity consumption in 2017-18, the industry sector accounted for the largest share (42.0%), followed by domestic (24.0%), agriculture (18.0%), and commercial sectors (8.4%). The electricity consumption in the industry and the domestic sectors has increased at a much faster pace compared to other sectors in the last decade with compound annual growth rates of 7.4% and 6.7%, respectively [5]. India needs to develop energy-efficient strategies focused on the residential sector to limit the current trend of unsustainable escalating energy demand. Thus, to reduce electric loads ‘energy-efficient affordable housing’ has been a key to facilitate the process of urbanization.

To reduce energy loads of the domestic sector, the upcoming construction must be designed with an optimal building design approach through bye-laws, building codes, and user manuals, i.e., the National Building Code, Model Building bye-laws, Handbook for functional requirements of the building, and Eco-Niwas Samhita (R) – 2018.

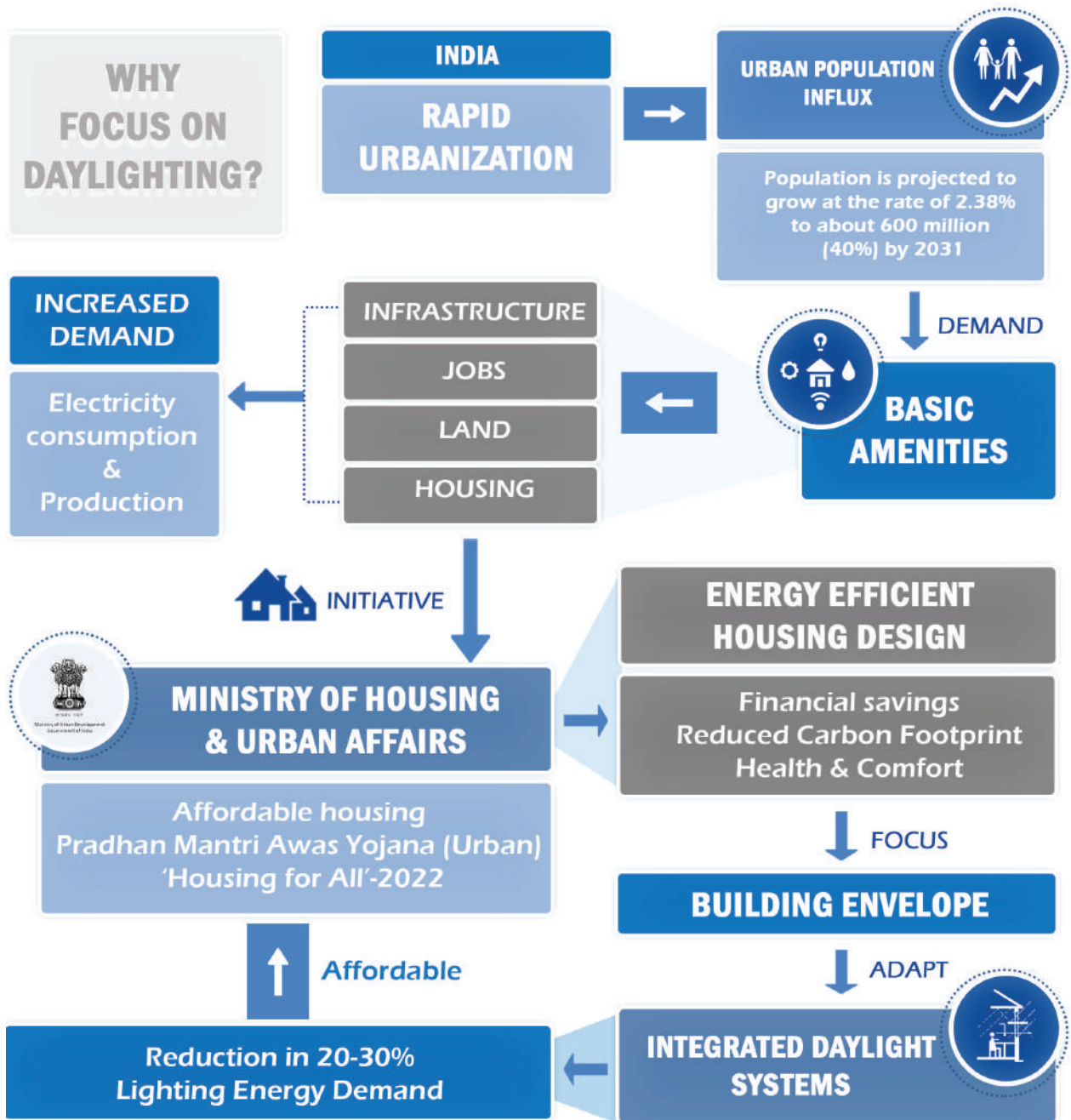

Figure 1: Why focus on 'daylighting' for affordable housing in India? [2] [5] [3]

It is studied that daylighting can significantly impact the energy use of a building by reducing 20–30% of the lighting energy demand [5]. In cooling dominated climate zones, heat gain should be given a lot of importance in building design which impacts thermal comfort and contributes to energy savings. The current practices of residential envelope design and construction practices show an immense variation in heat gains and hence in sensible cooling demand. According to Eco-Niwas Samhita-Residential, depending on the envelope design and construction adopted for residential buildings located in a particular climate zone, the minimum and maximum sensible cooling demand can vary by as much as 1:3.7 [6]. Therefore,

'daylighting' with effective shading strategies and glazing selection must be considered as an important aspect in the process of building envelope design of a residential building following the standards, policies, and available guidelines to minimize the cooling load, energy costs, and maximize illumination during daylight hours.

The crux of incorporating an advanced yet sustainable daylighting system is to significantly reduce a building's electricity consumption and to improve the quality of light in an indoor environment. There is no significant literature available in India that is completely devoted to daylighting for affordable housing with an understanding of the techno-economic performance evaluation of daylighting systems. This report will help in understanding these strategies which are another step forward in providing daylit, user-friendly, energy-efficient building environment. It is important to understand that these systems need to be integrated into a building's overall architectural strategy and should be incorporated into the design process from its earliest stage. Size and position of fenestrations, type of shading device, nature of the material, and the surroundings together impact daylighting in a building.

It is important to focus on the major objectives shown in Figure 2 for applying daylighting systems.

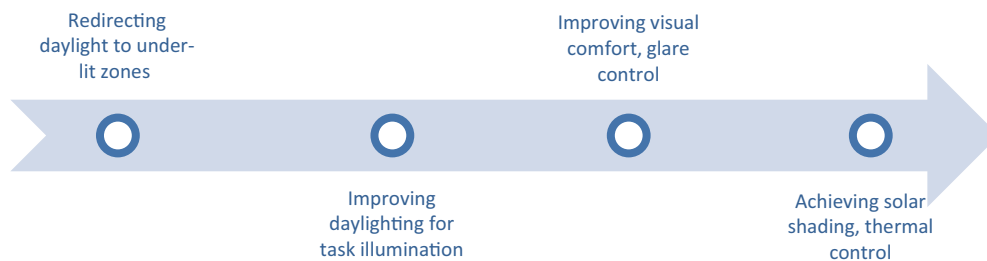

Figure 2: Objectives of applying daylighting systems

Daylighting: Definitions, Classification and Context

Definitions in Literature

Daylight is “the act of lighting the interior and/or exterior of a building with natural light” [6], “a natural source of light which can save energy” [7], “meets all the requirements of good lighting” [8], “have the ability to transform an internal space from uninspiring uniformity into a psychological uplifting experience” [9], “is the use of light from the sun and sky to complement or replace electric light” [10], “is important for its quality, spectral composition, and variability” [9], “links to higher comfort, productivity, and feeling of well-being” [11], “is the use of daylighting strategies to minimize operating costs and maximize output, sales, or productivity” [6], helps in the “conservation by offsetting electric lighting and its impact on heating and cooling loads” [12]. Consequently, “researchers consider daylighting at various scales, ranging from daylight-enhancing façade components” [13] to urban studies and have developed a variety of “daylight performance metrics that aim to quantify the different aspects of natural light” [13].

What do we understand by it?

There is no specific definition available in the literature to define a daylighting system. However, a study through the literature reveals the objectives of applying daylighting systems as mentioned in Figure 3.

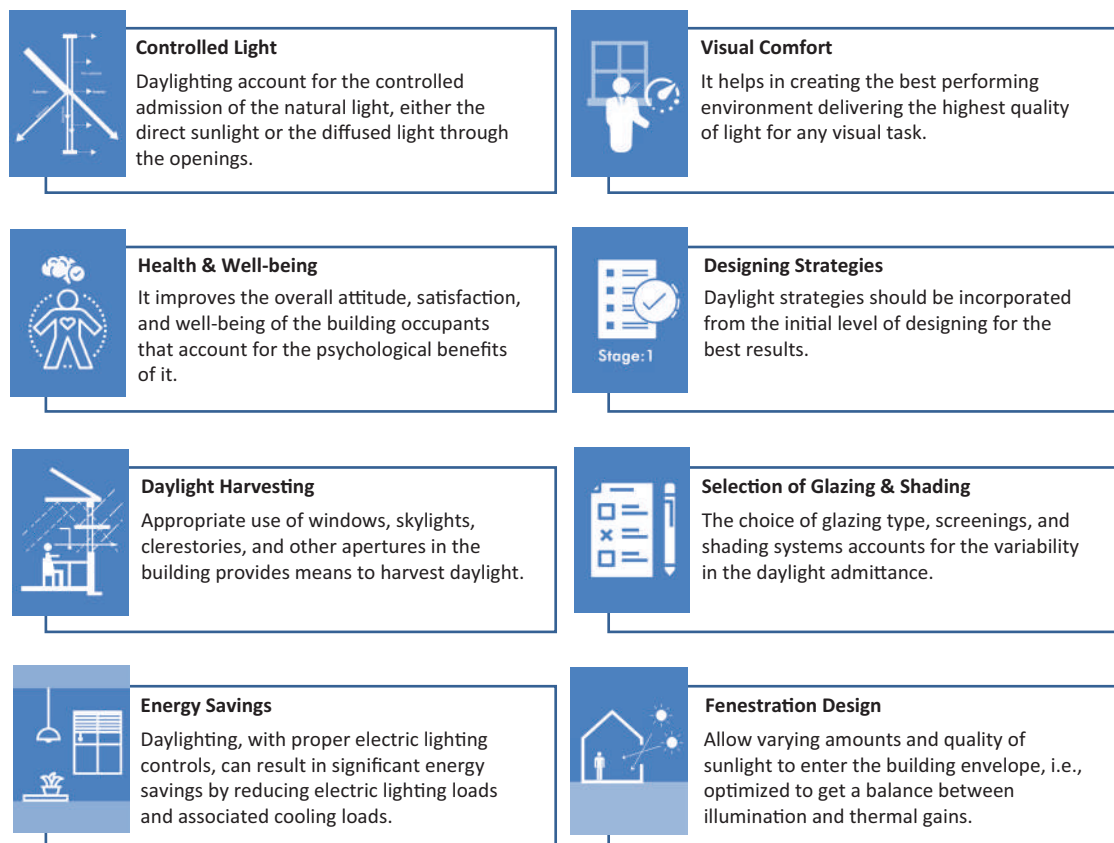

Figure 3: Objectives of applying daylighting systems

Thus, a combination of fenestration and shading system typologies applied to modulate the daylight admittance can be called as a **'daylighting system'**. It is considered along with an architectural response to site, climate, and patterns of use of electric lighting to provide a high-quality, visually appropriate, and energy-efficient indoor environment.

Classification of a daylighting system based on daylight admittance in a building

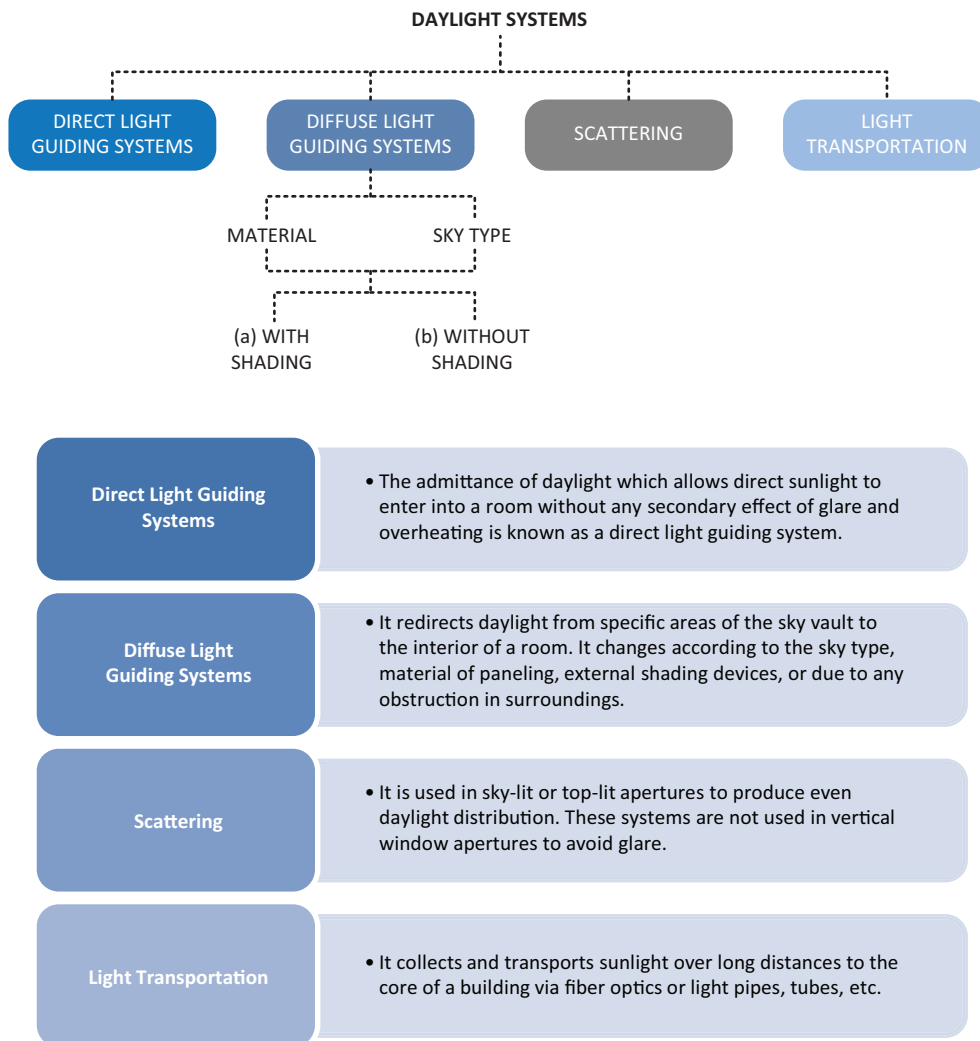

Figure 4: Classification of daylighting systems based on daylight admittance (Adapted & modified from ECBCS Daylight in Buildings Report) [9]

Daylighting System in the Indian Context

India has an extraordinary variety of climatic regions with a majority in cooling dominated climate zones. “Traditionally and historically, buildings in India were designed with courtyards to bring daylight into the core of the buildings and overhangs that were appropriately sized to shade the interior from the summer sun. After the advent of the air-conditioning systems and electric light, buildings were accordingly designed to have artificial ventilation and lighting systems” [14].

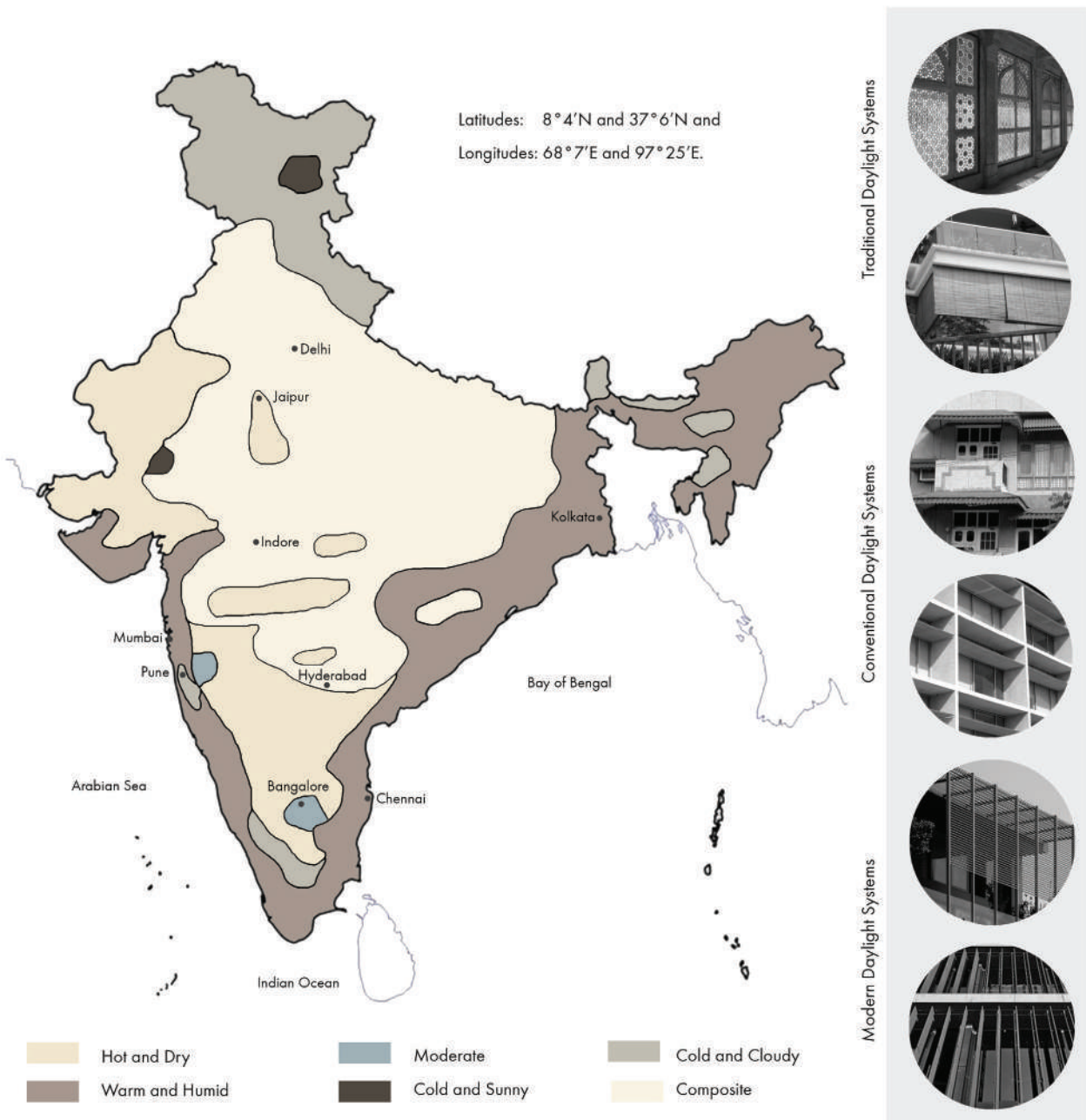

Figure 5: Climatic zones of India and hierarchy of shading systems

In India, the daylight systems can be broadly classified into three categories, i.e., traditional, conventional, and modern daylight systems. Certain guidebooks, manuals, codes, and standards such as ECBC-R, NBC, and SP41 provide guidelines for designing and incorporating daylighting strategies in an Indian residential building. Although, in these manuals there is no specific list of daylight systems, but they cover the aspects of building orientation, fenestration size, position, height, and glazing treatments along with the form and dimensions of shading devices and the technical parameters confined with it.

It is also important to understand that India being a culturally rich country has different styles of construction techniques and practices with aesthetical variations in buildings when it comes to local, traditional, and vernacular architecture. For example, patterned massive screen shading systems are mostly applied to vernacular building facades in hot climates to provide protection from direct sun and regulate social interaction [15]. Thus, one may approach different practices of daylighting systems in different climatic locations in the country.



Figure 6: Daylight system in India

Hence, it can be concluded that a combination of fenestration, glazing type, shading devices, wall finishes, internal geometry, and surface reflectance along with the design guidelines forms an integrated daylight system in India.



Classification of daylight system based on affordable housing in India

A daylight system for affordable housing in the Indian context is the juxtaposition of elements in a three-layer system consisting of the shading device (internal or external) and the fenestration (size, glass, frames, doors, etc.). The three-layer system can be further divided into the following:

1. The external layer being the 'shading' device
2. The intermediate layer being the 'fenestration' or the opening
3. The internal layer being the curtains or blinds that act as a 'visual barrier' or an 'internal shade'

Based on the performance of the daylight system and the assessment of the Indian market, i.e., the availability of resources, scalability, and the techno-economic parameters, a list of daylight system (but not limited to) was created in context to the three-layer system approach.

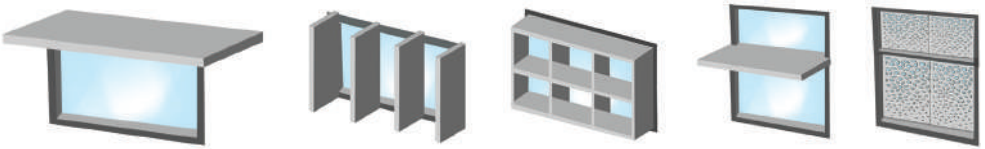
Table 1: Daylight system applicable to affordable housing in India (based on literature study)

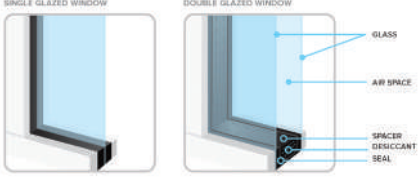
A. External Layer	
(a) External Shading	 <p>Awning/Overhang or chhajja Vertical louvers Egg-crate type Light shelves Jali screens</p>
B. Intermediate Layer	
(a) Fenestration - window	 <p>Fixed indow Sliding window Casement window Double hung window Folding window Bay window</p>
(b) Fenestration - frames	 <p>uPVC frame Aluminium frame Timber/Wooden Vinyl frames Composite frames (aluminium + vinyl/wood)</p>
(c) Fenestration - glass	 <p>Single glazed unit High performance glazing</p> <ul style="list-style-type: none"> • Clear glass • Tinted glass • Extra clear glass • Coated glass • Low E-glass
C. Internal Layer	
(a) Internal Shading Systems	<ul style="list-style-type: none"> • Curtains • Blinds (chick blinds/roller blinds) • Plantation shutters/screening
D. Other Consideration(s)	
(a) Building Obstructions	<ul style="list-style-type: none"> • Landscaping (deciduous trees, tall trees) • Neighbouring buildings • Outdoor surface reflectance

The three-layer designing system can be approached in several other ways due to growing innovation in the material sector and the technology. However, for an affordable designing option of a daylight system the key is to keep 'a balance' between these three layers. For example, a single glass layer might be a cheaper option but least energy efficient when it comes to heat ingress. In such cases, the shading design should be given a lot of importance to obtain less heat gain and more daylight during peak summers.

Parameters: Daylight Availability, Transmission and Calculations

During daytime when natural light is available in abundance, a window can be utilized as a tool to harness natural light from outside to light an indoor space. To better understand and design the daylight integration systems, firstly we need to realize certain parameters on which the daylight availability and its transmission depend. Some of these factors are explained further.

Latitude

One of the parameters to observe the amount of daylight entering any building is its location or the latitude. Since earth's axis is tilted 23.5 degrees from its orbital plane and is always pointed in the same direction while orbiting the sun, sunlight on different latitudes changes throughout the year. This also causes seasonal variations in the intensity of solar radiation and the number of daylight hours at a particular place.

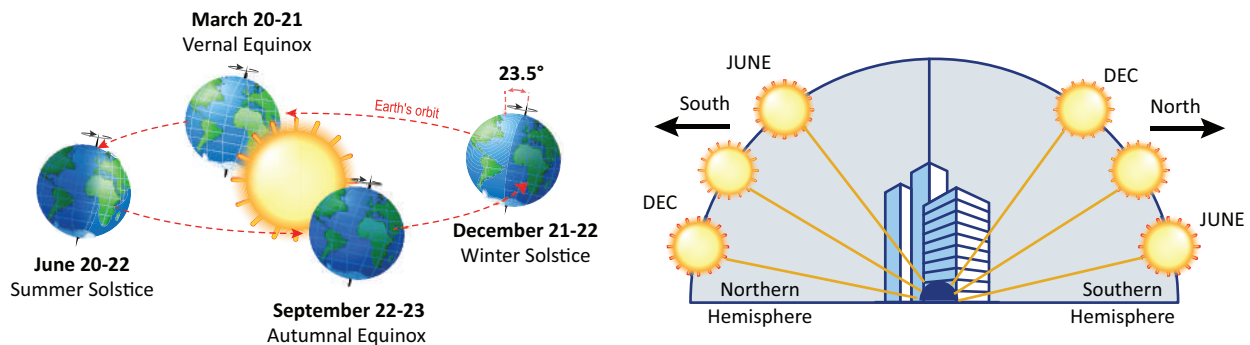

Figure 7: (L) Revolution of earth around the sun creating summer and winter solstice (R) Sun angles during summer and winter solstice

At equator, the line of 0 degree latitude, during half of the year the northern hemisphere is oriented towards the sun and during the other half the southern side gets the most sunshine. The sun movement shifts towards the south, as we move towards the Tropic of Cancer, 23 degrees north. Any place above 66.5 degrees north, one get sun for only 6 months and no sun for rest of the 6 months.

India lies in the northern hemisphere, with the mainland extending between latitudes 8°4'N and 37°6'N and longitudes 68°7'E and 97°25'E. In India, there are comparatively low sun angles during winters and high sun angles during summers as shown in Figure 7. This information helps in analysing the number of daylight hours available in a particular day, a month, or a year to design a daylight system.

Building Orientation, Shape, and Massing

The building orientation, shape, and massing play an important role at the conceptual stage of any building design. In cooling dominated climates of India, buildings that are placed along the east-west direction (longer axis having larger northern and southern facade) are better for daylighting and visual comfort as the sun angles are low during the sunrise and sunset which may cause a major glare problem along with less daylight hours.

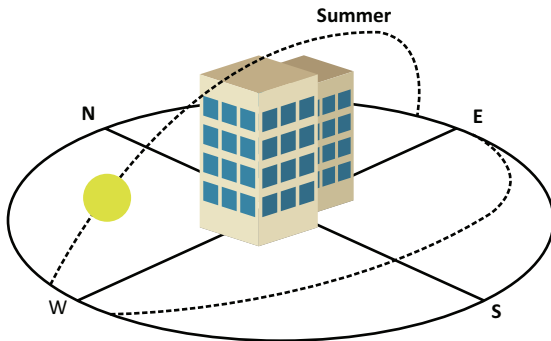

Factors that should be kept in mind while deciding the orientation of the building block are as follows:

- East-west longer axis and North-South larger façade
- Heat gain and daylight admittance to obtain maximum solar radiation during winter and minimum in summer
- Site surrounding conditions
- Wind analysis and sun path

Figure 8: East-west longer axis/north-south larger facade [16]

The depth of the floor plate, courtyard, and atriums plays an important role in designing a daylit building massing. A comparative analysis of potential daylight availability between different massing models is shown in Figure 9. This is explained in detail in the section 'Daylighting Tips and Thumb Rules' in this report.

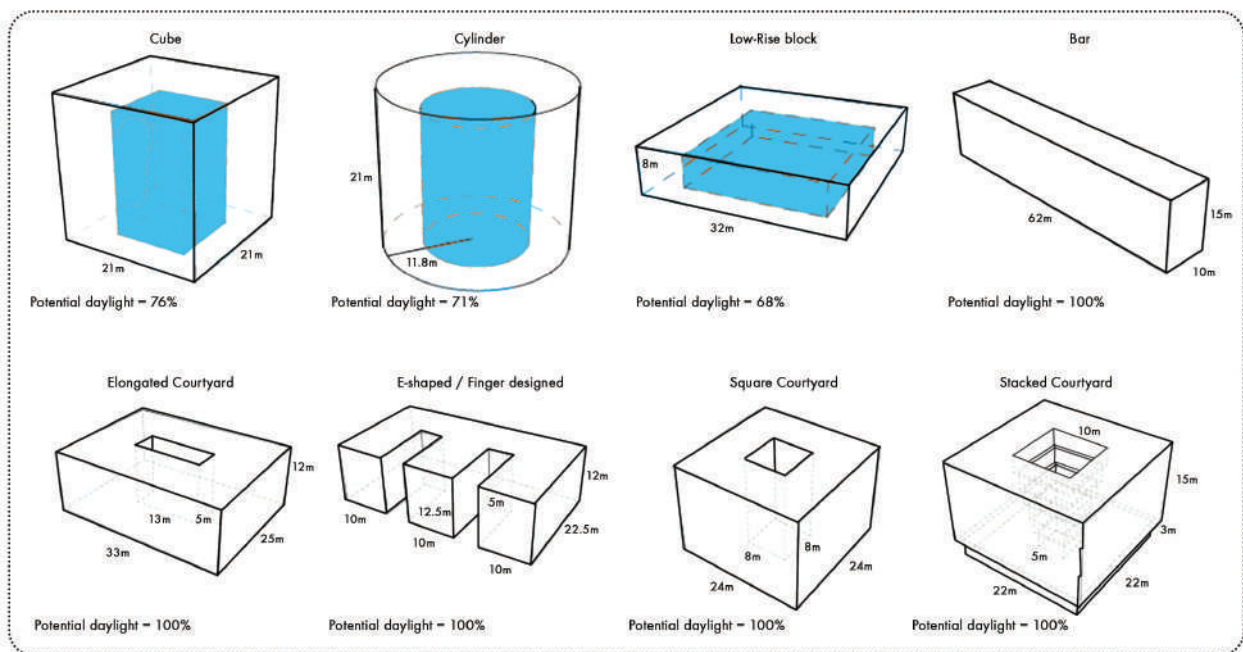

Figure 9: Massing studies for daylight area (Adapted from MIT open course work – Sustainable Building Design) [6]

Sky type

Scattering of sunlight in the atmosphere by air, water vapour, dust, etc., gives the sky the appearance of a self-luminous source of light. The illumination produced by the sky depends on its luminance and the amount of scattering of sunlight. When there are clouds, the sky's brightness distribution can change dramatically in a short time span [13]. Thus, it is necessary to devise an ideal sky brightness pattern known as the sky models which are used for the majority of daylight simulation applications. Every location experiences a different type of sky cover that results in variation in daylight availability.

The total solar radiation projected on any building is a combination of both direct and diffused solar radiation. It is, therefore, difficult for architects and engineers to be able to model the sky and accurately plan the daylight performance of buildings.

The CIE has made successful attempts to create such model skies that are a very valuable tool for professionals dealing in daylight.

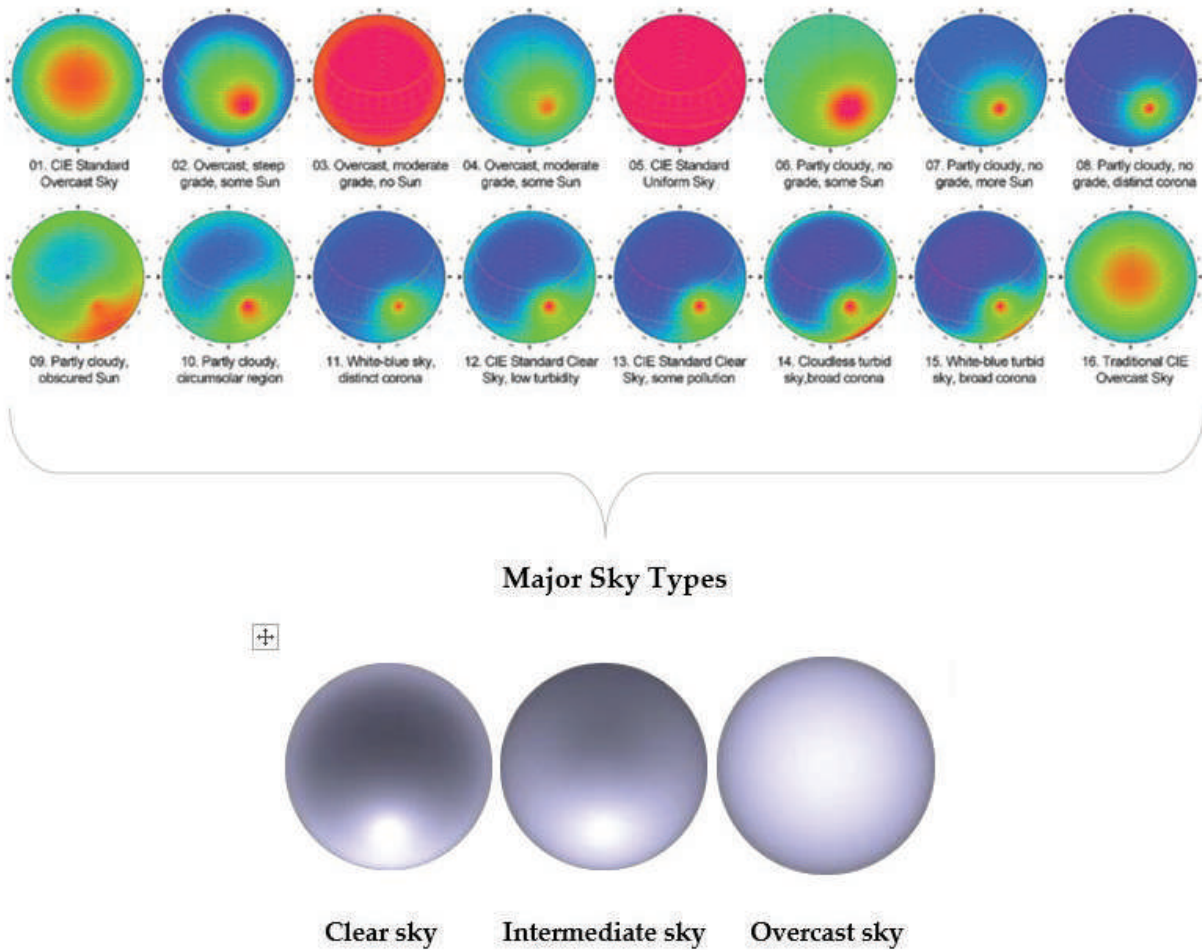

Figure 10: CIE sky model distribution [17]

These sky types can be broadly categorized into three main sky models: clear sky, intermediate sky, and overcast sky, also shown in Figure 10, which can be further sub-divided into 16 types of sky cover.

Clear sky

The luminance of the standard CIE clear sky varies over both altitude and azimuth. It is the brightest around the sun and the dimmest in the opposite direction. The brightness of the horizon lies in between those two extremes.

Intermediate sky

The standard CIE intermediate sky is a somewhat hazy variant of the clear sky. The sun is not as bright as with the clear sky and the changes in brightness are not as drastic.

Overcast sky

The luminance of the standard CIE overcast sky changes with altitude. It is three-times as bright in the zenith as it is near the horizon. The overcast sky is used to measure daylight factors. It can be modelled under an artificial sky.

Most of the daylight performance assessment is carried out over an overcast sky condition which is discussed in the section 'Daylight Performance Metrics' in this report.

Fenestration – Size

Fenestration is defined as an opening in a building envelope. Various functions in a building are performed through different fenestrations including windows, ventilators, glazed doors, and skylights. Their primary purpose is to provide access to the natural light into the indoor space. Presence of sunlight in a room in varying amount and quality can have physical and psychological impacts on the indoor environment and people in the room. The amount of light entering into a building is dependent on the 'window-to-wall area ratio'.

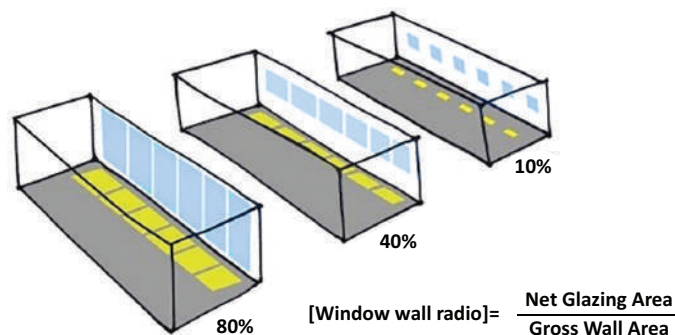

Figure 11: Variation in window-to-wall ratios [18]

Window-to-wall ratio: It is the ratio of the area of non-opaque building envelope components of dwelling units to the envelope area (excluding roof) of dwelling units. The greater the window-to-wall ratio (WWR %) more the light penetrates through the openings.

Another important factor to decide upon the WWR% or the size of the opening is the openable window-to-floor ratio (WFR_{op}). It provides a rough estimate for determining optimum areas of window in relation to the floor area of a room or house. As a general guide, the total window area should be less than 25% of the total floor area of the house [19]

The ECBC-R (2018) states that, 'Open-able window-to-floor area ratio indicates the potential of using external air for ventilation. Ensuring minimum WFR_{op} helps in ventilation, improvement in thermal comfort, and reduction in cooling energy' [20]. The minimum recommended value of WFR_{op} for residential buildings in India is as follows:

Where,

$$WFR_{op} = \text{Area (open-able)} / \text{Area (carpet)}$$

Table 2: Minimum requirement of window-to-floor area ratio for residential buildings in India [20]

Climatic Zone	Minimum WFR_{op}
Composite	12.50
Hot-dry	10.00
Warm-humid	16.66
Temperate	12.50
Cold	8.33

Fenestration – Glass

The glazing or the non-opaque material is one of the most important parameters that affect the transmission of daylight into a building. The classification of glass fenestration can be further divided into two categories where single pane glass can be considered as Category I, i.e., primary selection for any type of glazing system. Depending on the required performance of the glazing, the user might select multiple layers of single glass which are known as the double-glazed unit or triple-glazed unit system. This can be further divided into Sub-Category I classified into clear glass, tinted glass, coated glass, and extra clear glass. (Classification adapted from the inputs given by Glazing Society of India)

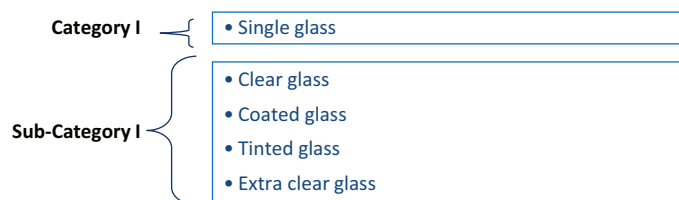

Figure 12: Fenestration glass – affordable housing classification [21]

For affordable housing in India, generally single-glazed system is adapted with a variation in Sub-Category I. Furthermore, high performance glazing with low-E glass can also be considered effective in a case of an energy-efficient affordable glazing solution. Most of the time the benefits of a glass are often underrated, thus they are often considered as factors that drive up the construction cost of an energy-efficient building. The inefficiencies in the building design eventually end up increasing the operational cost of a building as the designers do not have the understanding to select appropriate specification or combination of specification of the building envelope products.

Key Points

While selecting a glazing for an affordable housing design, attention should be given to the following:

- Selecting between single pane and high-performance single glazing.
- Selecting a spectrally selective glazing.
- Balancing the conflict between glare and light.
- Trading off window size and glazing selection.
- Not depending on glazing alone to reduce heat gain and discomfort.
- Selection of a frame for glazing.

Table 3: Suggested properties: Energy performance for single glass [21]

S. No.	Properties	Testing Standard
1.	Solar Factor (SHGC)	ISO 9050 / EN 410 / NFRC 200 / NFRC 300- 2 2017 / IS 16231-02
2.	Light direct transmittance	
3.	Shading co-efficient	
4.	U-value	ISO 9050 / ISO 15099 / IS 162331-02 / EN 673 and EN 12898 / NFRC 100

SHGC: Solar heat gain coefficient.

Table 4: Non-energy properties of a glass [21]

S. No.	Properties	Testing Standard
1.	Thickness and dimensions	IS 14900: 2018

*** All clear glass should be ISI marked as per IS 14900: 2018**

Table 5: Properties of fenestration-glass system [16]

Properties

1. Visible light transmittance - VLT (affecting daylight)

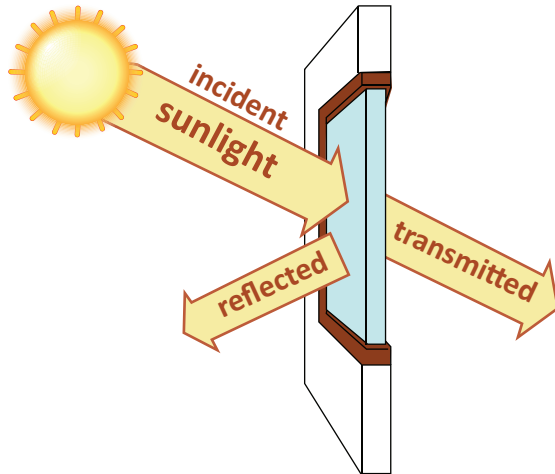

- ✓ VLT of non-opaque building envelope components (transparent/translucent panels in windows, doors, ventilators, etc.) indicates the potential of using daylight.
- ✓ The VLT requirement is applicable as per the window-to-wall ratio of the building.

2. Visible light reflectance - VLR (affecting heat and light reflection)

- ✓ VLR is the measurable amount of visible light that is reflected out by a glazing system.
- ✓ A glazing system with a high VLR means that most of the daylight is not passing through the window.

3. Thermal transmittance or U-value (affecting conduction heat gains)

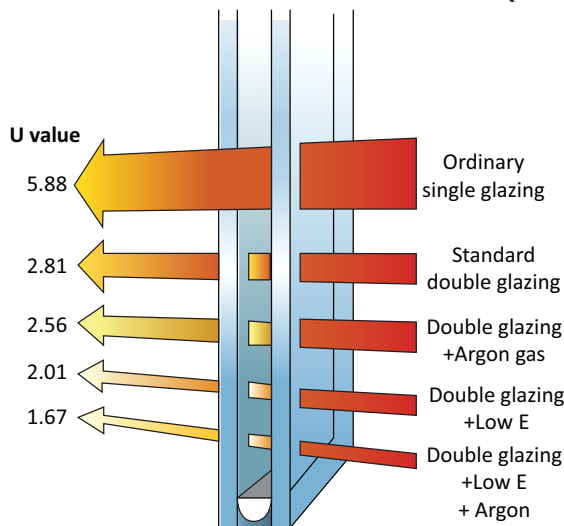

- ✓ Thermal transmittance (U-value) is the heat transmission in unit time through the unit area of a material or construction and the boundary air films, induced by unit temperature difference between the environments on either side.
- ✓ The unit of U-value is W/m² K. The U-value for a wall/roof/glazing indicates its ability to transfer heat through conduction.

Properties

4. Solar heat gain (affecting direct solar gain)

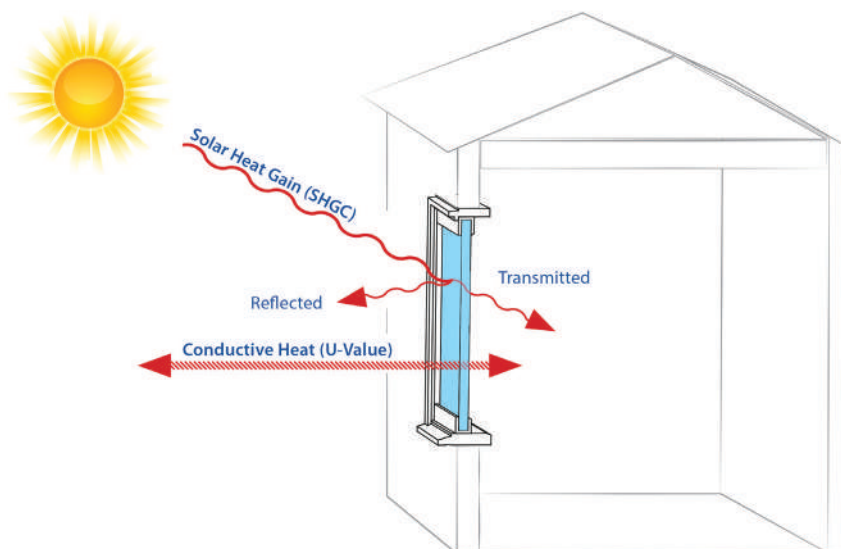

- ✓ SHGC: It is the fraction of incident solar radiation admitted through non-opaque components, both directly transmitted and absorbed and subsequently released inward through conduction, convection, and radiation.

5. Selectivity (affecting daylight and heat gain)

- ✓ The ratio of the VLT to the total solar energy transmission (g-value) $S = T_{vis}/g$
- ✓ A higher selectivity means sunlight entering the room is more efficient for daylighting, especially for summer conditions where more light is desired with less solar gain. This ratio is the measurement used to determine whether the glazing is 'spectrally selective'.

6. Glazing colour (affecting the thermal and visual properties of glazing systems)

SHGC: Solar heat gain coefficient; VLR: Visible light reflectance; VLT: Visible light transmittance.

ECBC-R (2018) code requires visual light transmittance (VLT) of non-opaque building envelope components to comply with the minimum VLT values as recommended in Table 8. Thus, the selection of the glazing system can be done keeping in mind the required value for VLT corresponding to the designed WWR%.

Table 6: Minimum requirement of VLT to desired WWR% for residential buildings in India [20]

Window-to-wall ratio	Minimum visual light transmittance
0-0.30	0.27
0.31-0.40	0.20
0.41-0.50	0.16
0.51-0.60	0.13
0.61-0.70	0.11

Values of VLT for some glazing materials are mentioned in Table 9 for a comparative analysis between different typologies of glass with their specific thicknesses.

Table 7: Diffuse transmittance of glazing [16]

Material	Thickness (mm)	Transmittance (visual light transmittance)
Clear glass	3	0.85
Wire cast glass	6	0.67
Heat-absorbing glass	3.2-3.5	0.62
Prismatic glass	3.6	0.76
Glass fibre-reinforced polyester sheet	2.0-3.0	0.60-0.40
Double glazing	3 mm each	0.72
Pattern glass (colourless)	3.2 mm	0.78

Shading

The use of fixed or movable devices to block, absorb, or redirect incoming light for purposes of controlling unwanted heat gains and glare is a function of the shading system. The main purpose to provide shading in a window is to obstruct, diffuse, or reduce the penetration of direct solar radiation majorly during summer days and provide shade to the indoor space. This helps to reduce heat gain in a building thereby decreasing overall loads.

Shading devices are important design elements of glazed facades to reduce energy consumption of buildings and to optimize thermal and visual comfort of occupants. Shading devices may be attached to the interior or exterior facade surfaces to control daylight, solar heat gains, glare, view, and heat loss through facades.

External fixed shading can be categorized majorly into four typologies as mentioned below:

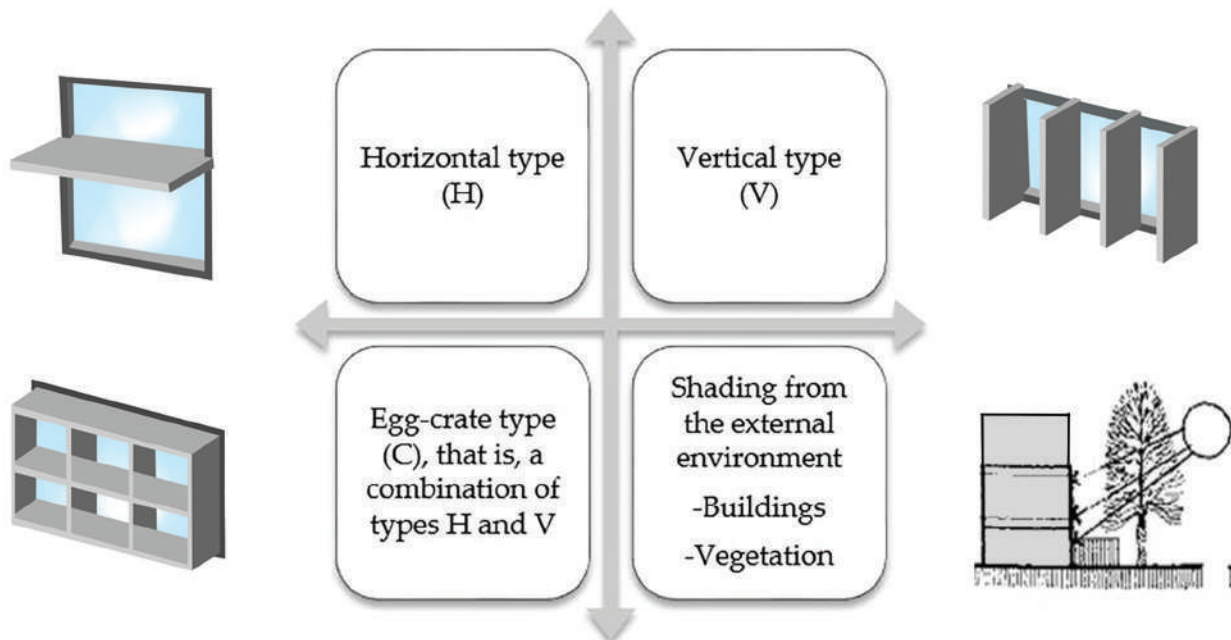

Figure 13: Main shading typologies [16]

The building orientation with respect to sun and external shading systems should be given a lot of importance (discussed more in section: Design & Thumb rules). This is a major issue which is overlooked by most of the designers and developers. To evaluate the performance of and the effectiveness of these external shading devices these are evaluated in terms of solar heat gain coefficient (SHGC_{eq}) and U-value.

To calculate the effectiveness of any shading device projection factor (PF) of permanent external projection, including but not limited to overhangs, side fins, box frame, *verandah*, balcony, and fixed canopies can be calculated in order to obtain the SHGC equivalent of the shading system. First, the PF overhang/side fin is calculated which is the ratio of the horizontal depth of the external shading projection to the sum of the height of a non-opaque component and the distance from the top of the same component to the bottom of the farthest point of the external shading projection, in consistent units [20].

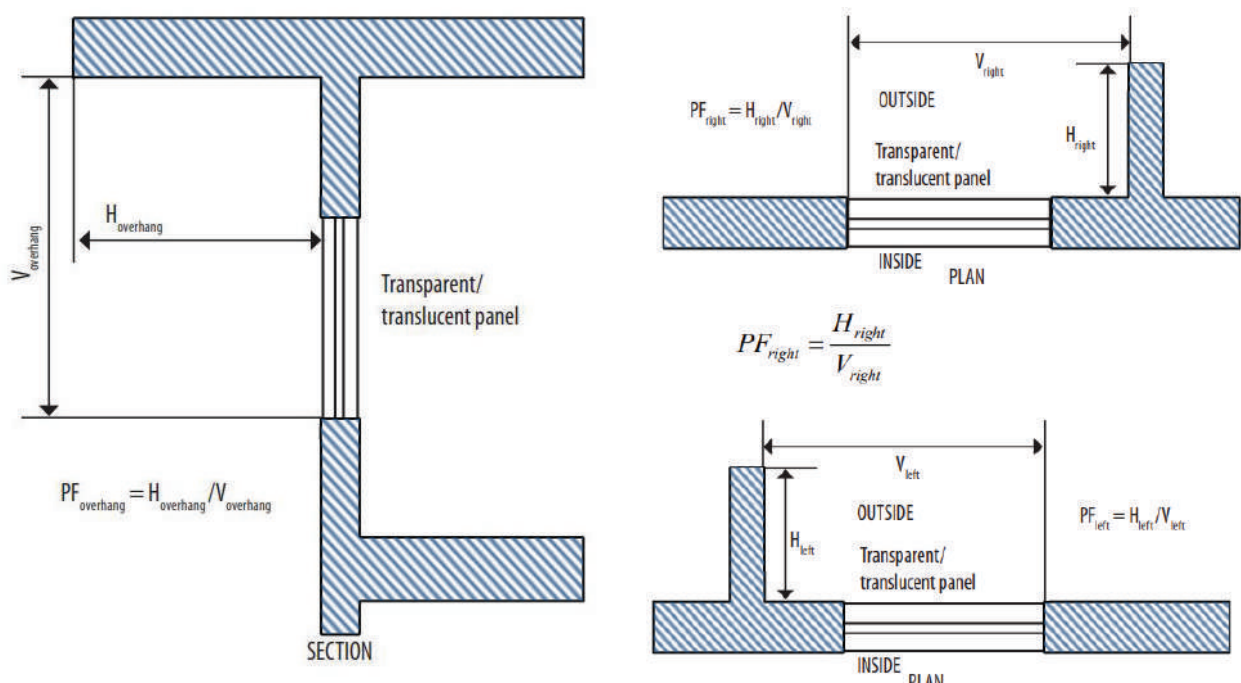

Figure 14: (Right) Projection factor for overhangs and (Left) side fins (Modified from ECBC-R 2018) [20]

After calculating the PF, depending upon the location of the housing, select the external shading factor (ESF) values from Tables 14 and 15 (Annexure 1) for overhangs and refer to Tables 16 to 19 (Annexure-1) for side fins (right or left) to the corresponding latitude.

Where,

$$\text{The total external shading factor is } \mathbf{ESF_{total} = ESF_{overhang} \times ESF_{side-fin}}$$

$$\text{and, } \mathbf{ESF_{side-fin} = 1 - [(1 - ESF_{right}) + (1 - ESF_{left})]}$$

After calculating the ESF_{total} , the SHGC_{eq} is calculated by multiplying the SHGC of the unshaded fenestration product ($SHGC_{unshaded}$) of the glass with the total external shading factor (ESF_{total}), using the following formula [20]:

$$\mathbf{SHGC_{eq} = SHGC_{unshaded} \times ESF_{total}}$$

For external moveable shading system (EMSYS), the Solar heat gain coefficients are mentioned in the Table-8

Table 8: Solar Heat Gain Coefficient (SHGC) for various EMSYS typologies. [22]

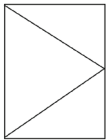
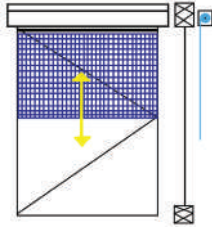
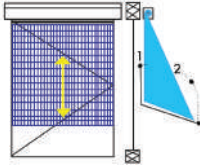
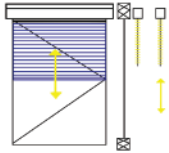
Clear glass Single 0.88 Double 0.75					
Typology	Shutters	Roller Blinds	Vertical Awnings / Chicks	Projection Awnings	External Lamella Blinds
SHGC	0.1	0.1	0.1-0.25 (Choice of textile fabric)	0.1-0.25 (Choice of textile fabric)	0.08-0.15

Building: Obstructions and surface reflectance

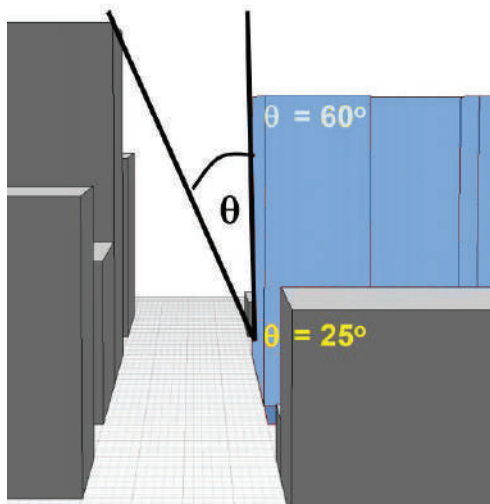

Figure 15: Sky angle [6]

At any site the sky is usually obstructed by surrounding buildings and vegetation. By determining the sky angle a designer can understand the daylight potential of the building's facade and hence can allocate the rooms as per daylight availability. The sky angle is the angle from the reference point on the facade in the glazing centre [6].

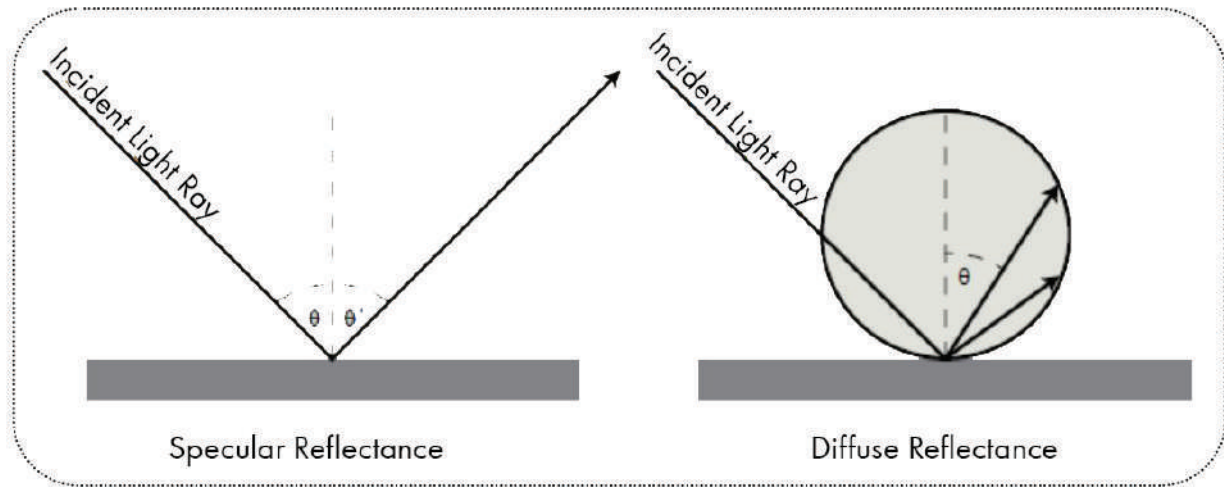

Figure 16: Surface Reflectance [6]

The internal and external surface reflectance of a building also affect the daylight admittance. Depending on the material used indoor or on to the shading device the daylight will be reflected inside the building which could enhance or decrease the amount of daylight in an interior space.

Table 9: Surface reflectance range as per Standard Codes and Rating Systems

Parameter	Codes/Rating System	Range			
		Ceiling	Walls	Floors	Furniture
Reflectance	EN 12464-1	0.7–0.9	0.5–0.8	0.2–0.4	0.2–0.7
	CIBSE Code for lighting	0.7–0.9	0.5–0.8	0.2–0.4	0.2–0.7
	LEED v4.1 Interior Design	85%	60%	25%	Work surfaces: 45% Movable Partitions: 50%
	The WELL Building Standards v 1 with May 2016 addenda	≥0.8	≥0.7		≥0.5
	NBC 2016	For ceilings and walls			
		Dark colours: 0.1	Middle tints : 0.3	Light colours: 0.5	White and very light colours: 0.7

Building: Envelope

The overall impact of the parameters; the latitude, orientation, fenestration-size, glazing and shading and the construction assemblies formulates the building envelope. The trade-off between size of glazing, VLT depending upon the selection of glazing, heat transmission- conductive and infiltration versus cost is the key to finding the right 'balance'. The energy-efficiency of a residential project can be evaluated by calculating the Residential Envelope Transmittance Value (RETV) which is the net heat gain rate (over the cooling period) through the building envelope of dwelling units (excluding roof) divided by the area of the building envelope (excluding roof) of dwelling units. Its unit is W/m^2 [20].

Table 10: Residential Envelope Transmittance Value (RETV) formula [20]

$$RETV = \frac{1}{A_{envelope}} \times \left[\begin{aligned} & \left\{ a \times \sum_{i=1}^n (A_{opaque_i} \times U_{opaque_i} \times \omega_i) \right\} \\ & + \left\{ b \times \sum_{i=1}^n (A_{non-opaque_i} \times U_{non-opaque_i} \times \omega_i) \right\} \\ & + \left\{ c \times \sum_{i=1}^n (A_{non-opaque_i} \times SHGC_{eq_i} \times \omega_i) \right\} \end{aligned} \right]$$

$A_{envelope}$: Envelope area (excluding roof) of dwelling units (m^2)

A_{opaque} : Areas of different opaque building envelope components (m^2)

U_{opaque} : Thermal transmittance values of different opaque building envelope components ($W/m^2.K$)

$A_{non-opaque}$: Areas of different non-opaque building envelope components (m^2)

$U_{non-opaque}$: Thermal transmittance values of different non-opaque building envelope components ($W/m^2.K$)

SHGC_{eq}: Equivalent solar heat gain coefficient values.

ω : Orientation factor of respective opaque and non-opaque building envelope components (Annexure 1)

Coefficients : (a, b, and c) for RETV formula (Annexure 1)

Daylight Performance Metrics

The daylight performance metrics helps in determining the daylight availability and its performance in any indoor space with respect to the parameters discussed in the section 'Parameters: Daylight Availability, Transmission and Calculations'. The parameters include site-specific conditions, dynamic interactions between buildings, use of the building by its occupants, and the surrounding climate considered on an annual basis.

Daylight Factor

Daylight factor (DF) is defined as the ratio of interior illuminance to outdoor illuminance at the same time under an overcast sky condition. The DF is a commonly used measure for calculating the subjective daylight quality and availability in a room. The higher the DF, the more natural light is available in the room. The DF is depended upon the latitude; hence, DF is different for a same type of building constructed at different locations due to a change in outdoor illuminance.

It is expressed as,

$$DF = 100 * E_{in} / E_{ext}$$

E_{in} = inside illuminance at a fixed point

E_{ext} = outside horizontal illuminance under an overcast (CIE sky) or uniform sky

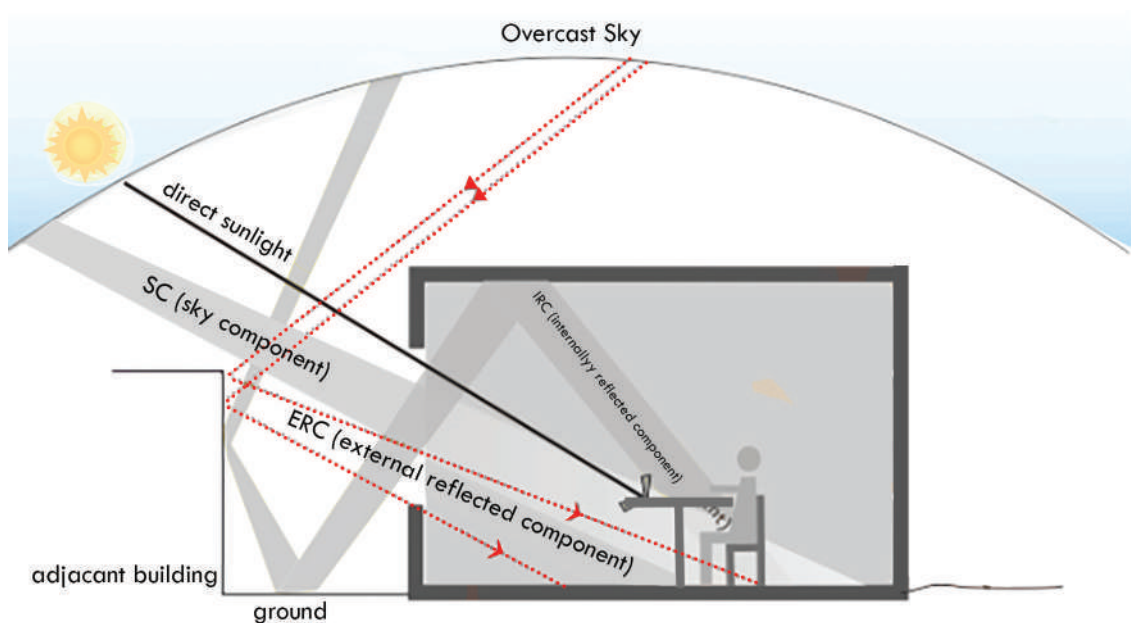

Figure 17: Daylight factor illuminance [23]

Table 11: Recommended value for illumination and daylight factor for residential space [16]

Recommended values of illumination for residential space (lux)		
1.	Kitchens	200
2.	Bathrooms	100
3.	Stairs	100
4.	Workshops	200
5.	Garages	70
6.	Sewing and darning	700
7.	Reading (casual)	150
8.	Homework and sustained reading	300
Recommended daylight factors for residential space (%)		
1.	Kitchen	2.5
2.	Living room	0.625
3.	Study room	1.9
4.	Circulation	0.313

Daylight Autonomy

One of the metrics is the daylight autonomy (DA) which was first mentioned in 1989 by the Swiss norm [24] and redefined by Reinhart and Walkenhorst in 2001 [25]. It is defined as the percentage of the occupancy time during the year when a minimum illuminance threshold is met by daylight alone considering overcast sky conditions throughout the year [26]. In simpler terms, DA is the percentage of annual work hours during which all or part of a building's lighting needs can be met through daylighting alone. This helps in designing a space to maximize the amount of useful daylight, and thereby minimize or eliminate the need for supplemental electric light. Therefore, the higher the DA value, the lower the switching on time of electric lighting, which means higher the energy savings.

Continuous and Spatial Daylight Autonomy

Continuous daylight autonomy (DA_{con}) is an extension of the DA metric, which was proposed by Zack Rogers in 2006 [25]. This metric is defined as the percentage of the occupied time during the year when a minimum illuminance threshold is met by daylight alone, considering a partial credit linearly to values below the threshold defined [26].

Whereas, spatial daylight autonomy (sDA) is defined as the percentage of floor area that receives at least 300 lux for 50% of the annual occupied hours [27]. This concept does not refer to a given point and cannot be categorized under dynamic daylight performance metrics because it analyses daylight use for an entire surface.

Generally, sDA (300 lux, 50%) >50% is accepted as already discussed but, sDA (300 lux, 50%) >75% is preferred and considered better.

Note: DA contains no upper limit on illuminance levels, so spaces with too much direct sunlight may also have higher sDA levels, but may not imply a comfortably lit space.

There is a wide range of daylight metrics available with no link between them. This in turn makes it difficult for designers to choose a suitable metric when assessing the potential of natural light of an architectural space. To understand the daylight performance metrics better, a relation between the DF, the minimum DA, and the illuminance threshold is demonstrated further for different latitudes. The daylight availability changes with the change in latitude for a constant DF and illuminance threshold.

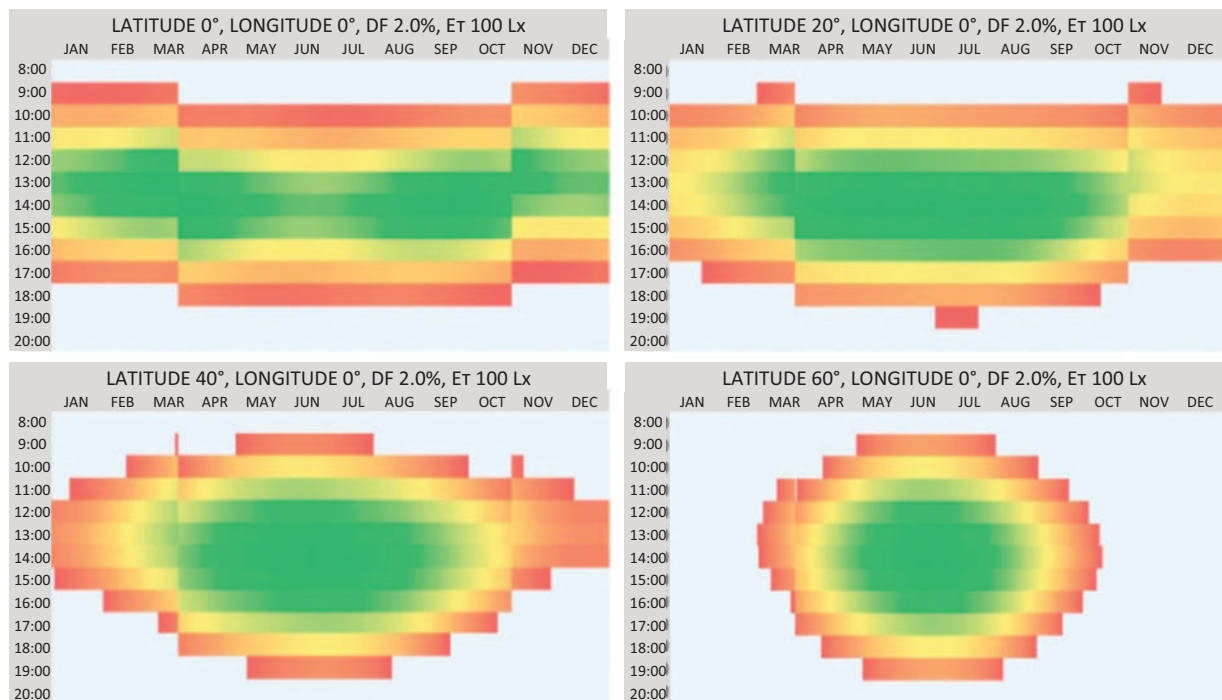

Figure 18: Calculation of minimum daylight autonomy for different latitudes, a daylight factor of 2%, and an illuminance threshold of 100 lux [28]

Useful Daylight illuminance and Climate-based daylight modelling

The DF method for assessing the daylight performance is nearly 50 years old and has persisted in the market as one of the dominant evaluation metrics for daylighting because of its simplicity and direct approach [26]. Despite the lack of realism, designers have become accustomed to the DF method and design manuals following the calculation-based approach with a list of recommended minimum DFs for various settings or tasks. But, today the advances in computer simulation allow for the possibility of daylighting analyses that are based on hourly or sub-hourly predictions of internal illuminance for a full year. For these approaches, the hourly sun and sky conditions are derived from basic irradiance quantities found in meteorological datasets based on the sky model data collected with the help of simulation-based software such as Autodesk Ecotect, ReLux, DiaLux, Diva for Rhino, etc.

For a calculation-based approach, the daylight illuminance uniformity that comes from using the standard overcast sky paradigm is inapplicable for realistic conditions where the contribution of direct sunlight leads to large differences between the maximum and the minimum daylight levels. And, this can only be achieved by abandoning the notion of a target illuminance [29].

To overcome this issue, a new approach towards the evaluation came into practice known as the useful daylight illuminance (UDI). UDI is the percentage of time for which a space receives adequate daylight. Lux levels between 100 and 2000 are considered to be adequate lighting for visual comfort. Furthermore, instances when lux levels are below 100 may be classified as low daylight illuminance, and instances when lux levels are above 2000 lux may be classified as high daylight illuminance.

$$\text{UDI} = \frac{[(X1 \times X2) \times (Y+2)]}{(\text{Area of the Room})} \times 100$$

Where,

X1: Daylight extent factor,

X2: Head height of window, and

Y: Width of the fenestration.

Key Points

- The illuminance is considered at the point in a space between the lower and the upper threshold illuminance requirement of any space.
- If the daylight illuminance is too small (i.e., below a minimum), it may not contribute in any useful way to either the perception of the visual environment or in the carrying out of visual tasks.
- Conversely, if the daylight illuminance is too great (i.e., above a maximum), it may produce visual or thermal discomfort, or both, causing the occupant(s)
- The higher value of the useful daylight illuminance contributes to the availability of daylight and reflects in its performance.

Annual Sunlight Exposure

It is a percentage of the analysis area (space) that exceeds a specified direct sunlight illuminance level for more than the specified number of hours for the course of the experiment.

Annual sunlight exposure (ASE)_{1000/250h} = Percentage of a space that exceeds 1000 lux for 250 (~10%) of the occupied hours.

Table 12: Daylight performance assessment benchmarks for residential buildings by various green rating system in India

S. No.	Rating System	Daylighting Benchmarks
1	GRIHA V. 2015	<ul style="list-style-type: none"> ▪ Maximum WWR% = 60% ▪ Maximum SRR% = 5% ▪ The mean DA requirements (100* lux or more) should met over the total living area for at least 25% of total annual analysis hours ▪ The mean DA requirements (3000 lux or more) should never exceed over the total living area for across the total annual analysis hours
2.	IGBC Rating System for green affordable housing (2017)	<ul style="list-style-type: none"> ▪ Achieve minimum glazing factors for at least 50% of the regularly occupied spaces in each dwelling unit ▪ Glazing Factor = $\frac{\text{Window Area (sqm)} \times \text{Actual VLT of glass} \times \text{Constant} \times 100}{\text{Floor Area (sqm)}}$ <p>Where, constant values for windows on wall = 0.2 and window on roof (skylight) = 1.0</p> <ul style="list-style-type: none"> ▪ Glazing factor values for: <ul style="list-style-type: none"> ✓ Living/Bedroom = 1 ✓ Multi-purpose room = 1 ✓ Kitchen = 2 ▪ Simulation approach: Daylight illuminance measurement for 50% of the regularly occupied spaces in the building should achieve daylight illuminance levels for a minimum of 110 lux
3.	WELL Building Standard-Multifamily Residential	<ul style="list-style-type: none"> ▪ Spatial daylight autonomy (sDA300, 50%) is achieved for at least 55% of the regularly occupied space. In other words, at least 55% of the space receives at least 300 lux of daylight for at least 50% of the operating hours each year. ▪ Annual sunlight exposure (ASE1000, 250) is achieved for no more than 10% of the regularly occupied space. In other words, not more than 10% of the area can receive more than 1000 lux for 250 hours each year ▪ Window/wall ratio, as measured on external elevations, is: <ul style="list-style-type: none"> ✓ Between 30% and 60% in living rooms ✓ Between 20% and 40% in bedrooms
4.	LEED V4. Residential-Multifamily	<ul style="list-style-type: none"> ▪ Minimum access to daylight in each living space: Achieve a minimum of 10 lux of daylight for at least 90% of the floor area of each regularly occupied space in all residential units ▪ Adequate daylight for the building: Achieve levels between 150 and 5000 lux for at least 50% of the regularly occupied floor area ▪ Spaces that incorporate blinds or shades for glare control may demonstrate compliance for only the minimum 150 lux level. ▪ Quality views: For at least 50% of the regularly occupied spaces in each residential unit, have one window that includes one of the following: (1) flora, fauna, or sky; or (2) objects at least 25 feet from the exterior of the window ▪ Views into interior atria may be used to meet up to 30% of the required spaces in the building

DA: Daylight autonomy; SRR: Skylight-roof-ratio; WWR: Window-to-wall ratio

Daylighting: Tips and Thumb Rules

Day-lit area for massing studies

Window head height: The rule of 2.5

The higher the window head, the deeper will be the penetration of daylight. As a general rule of thumb, the depth of daylit zone is typically 1.5–2-times the window head height. (Figure-20). If a space does not require the use of a shading device, the ratio range can increase up to 2.5-times.

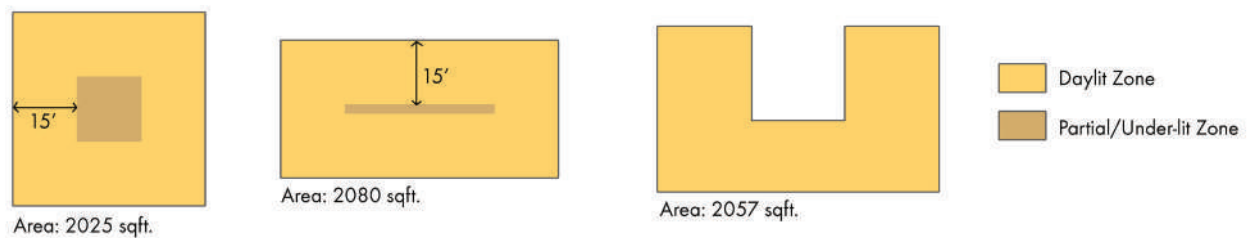

Figure 19: Daylit area for massing studies for different shapes of floor plan having similar floor area considering lintel level at 7 feet [6]

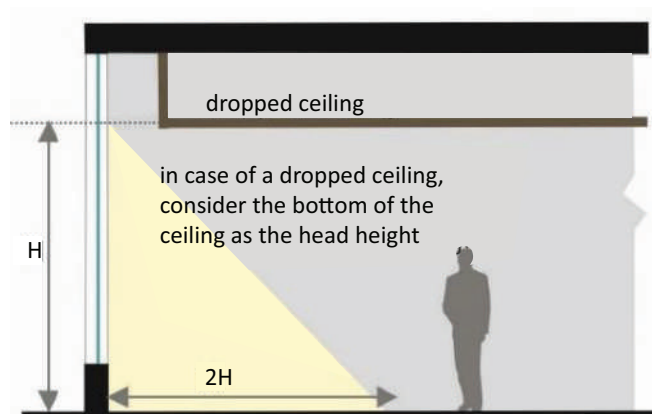

Figure 20: Daylight area window head height thumb rule (section) [11]

In addition to this rule, the daylit area for vertical fenestrations (with or without punched windows), majorly rectangular and square-shaped windows, can be easily evaluated by taking an offset of 1 m along the width of the window and two-times the height of the window on the floor plan. As shown in Figure 21, the daylit area extends 'a horizontal dimension equal to the width of the window plus either 1 m (3.3 ft) on each side of the opening, the distance to the opaque partition, or one-half the distance to an adjacent skylight or window, whichever is least [11].

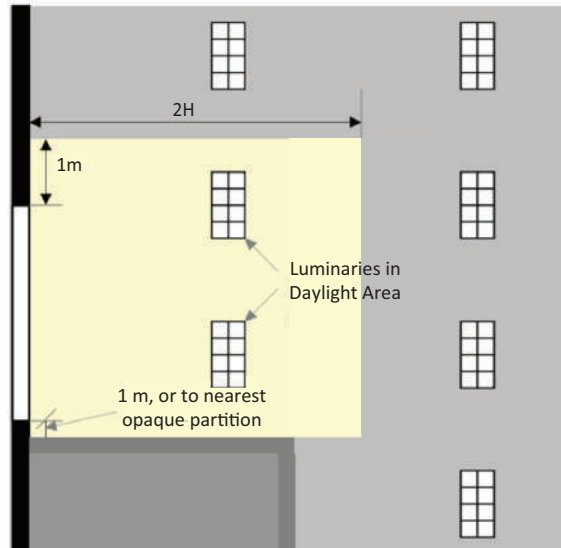

Figure 21: Daylight evaluation thumb rule for rectangular or square windows [11]

Atrium rule of thumb

To daylight all spaces bordering an interior atrium with diffuse daylight, the maximum atrium height should be about 2.5-times its width.

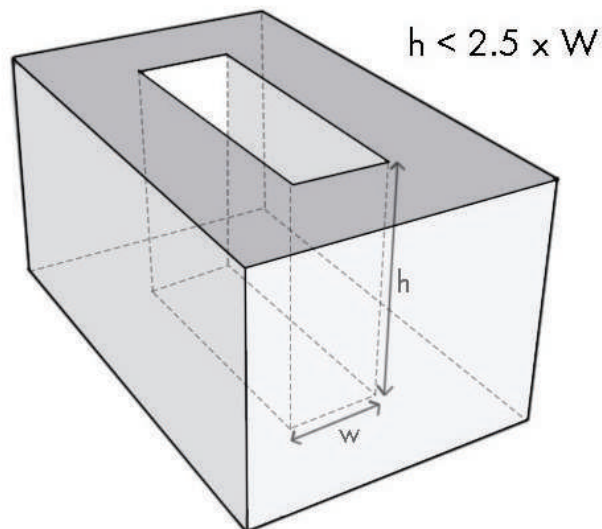

Figure 22: Atrium rule of thumb [6]

The 15/30 rule of thumb

As per the 15/30 rule, illumination level due to daylight is sufficient for the tasks within the first 15 feet from the window, and 50% benefit of daylight happens within the next 15 feet, while areas deeper than 30 feet receive no benefit of daylight [30].

Window design tips

Height of windows

- Taller windows provide greater penetration while broader windows allow better distribution of light.

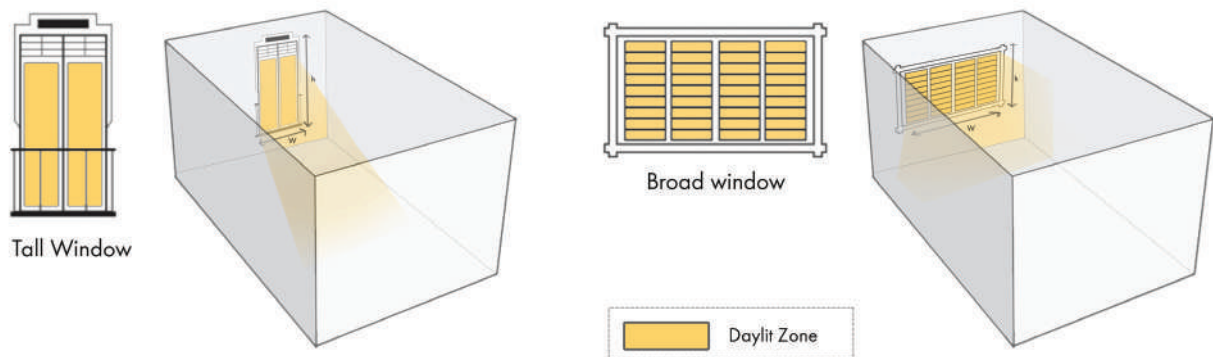

Figure 23: Tall versus broad windows [16]

- Sill height:** For carrying out a task while standing or squatting on the floor, suitable work plane levels are 1.0 and 0.3 m high, respectively. Since the part of a window below the work plane does not contribute significantly to the work plane illuminance, a sill height slightly greater than or equal to the height of the work plane above the floor level is desirable. The optimum sill for good illumination as well as good ventilation should be between the illumination work plane and the head level of a person [16].

Placement of windows

- Windows on two opposite sides allow greater uniformity of internal daylight illumination especially when the room is at least 7-m high. This also helps in improving ventilation.

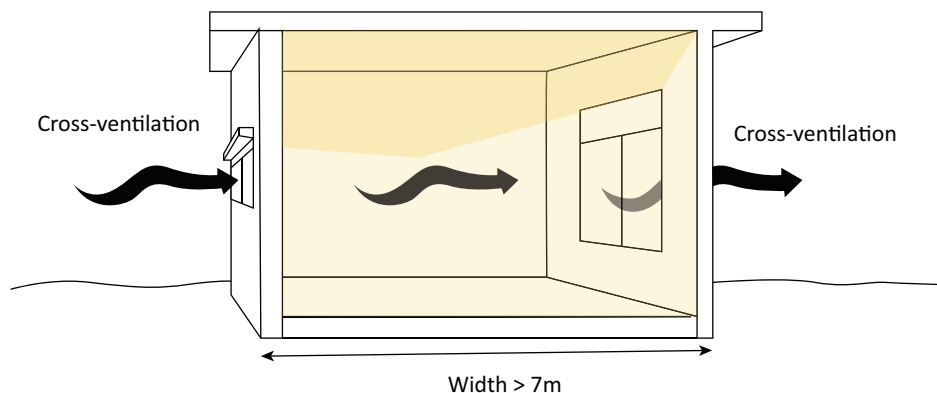

Figure 24: Opposite side windows give greater uniformity of daylight and improves ventilation [16]

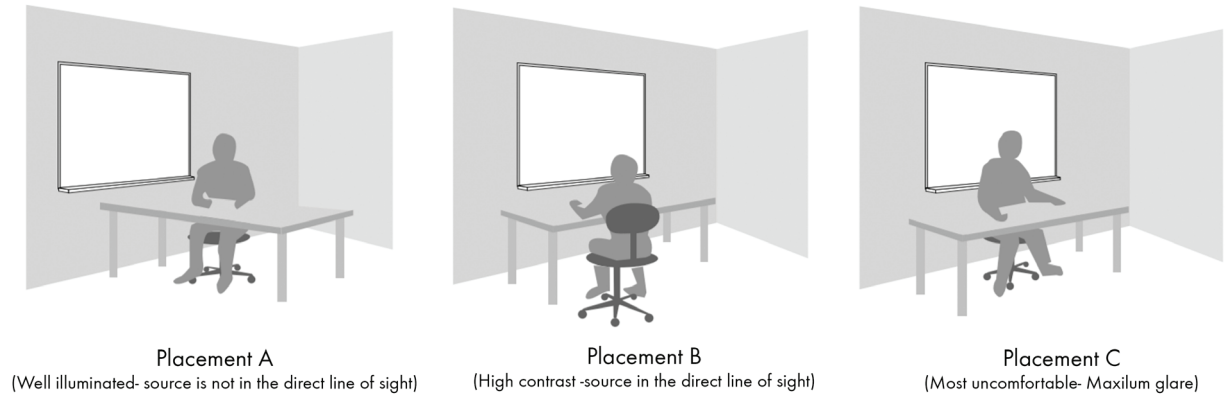

Figure 25: Placement of work areas [10]

- Small horizontal openings close to the floor and the ceiling are extremely effective in reducing the window area to bring down heat ingress and provide adequate daylight levels in the space.
- Large openings on north and north-east facades help light to reach deeper areas and smaller windows on east and west directions due to low sun angles at sunrise/sunset to avoid glare probability.
- Use skylights and roof monitors in areas without easy access to windows.
- Strip windows are an easy way to provide uniform daylighting. Whereas, punched windows should be paired with work areas to avoid creating contrasts of light and dark areas.

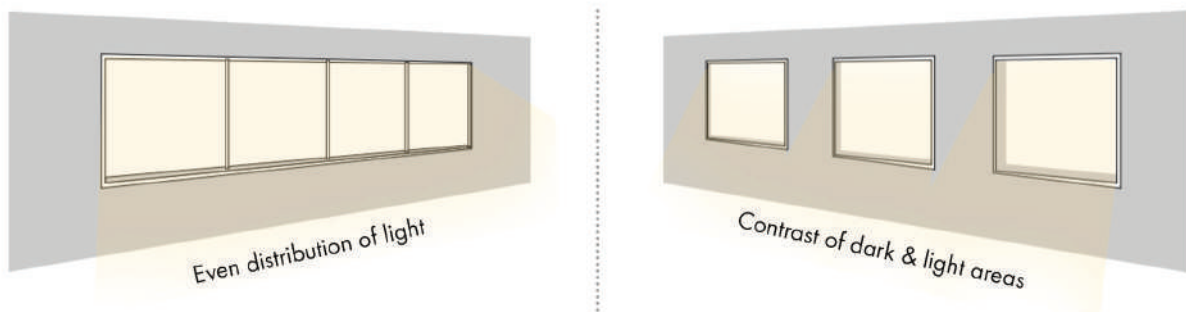

Figure 26: Strip versus punched windows [16]

Shading: Thumb rules

Some of the best practices for external shading as per façade orientation in India are as follows:

North or South	East or West	North-East or North-West	South-East or South-West
<ul style="list-style-type: none"> • Fixed or adjustable shading placed horizontally above windows 	<ul style="list-style-type: none"> • Adjustable vertical screens outside windows 	<ul style="list-style-type: none"> • Adjustable vertical or combination shading 	<ul style="list-style-type: none"> • Horizontal shading (fixed or adjustable) • Planting

Figure 27: Placement of shading devices as per façade's direction for external shading. [23]

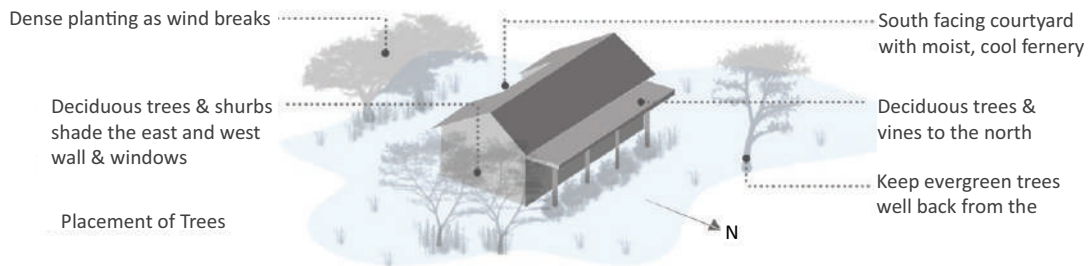

Figure 28: Placement of trees as per façade's direction for external shading (modified and adapted from NBC-2016) [16]

- It is desirable to break a single overhang with larger depth into multiple overhangs of smaller length. It enhances the amount of daylight penetration into the space.

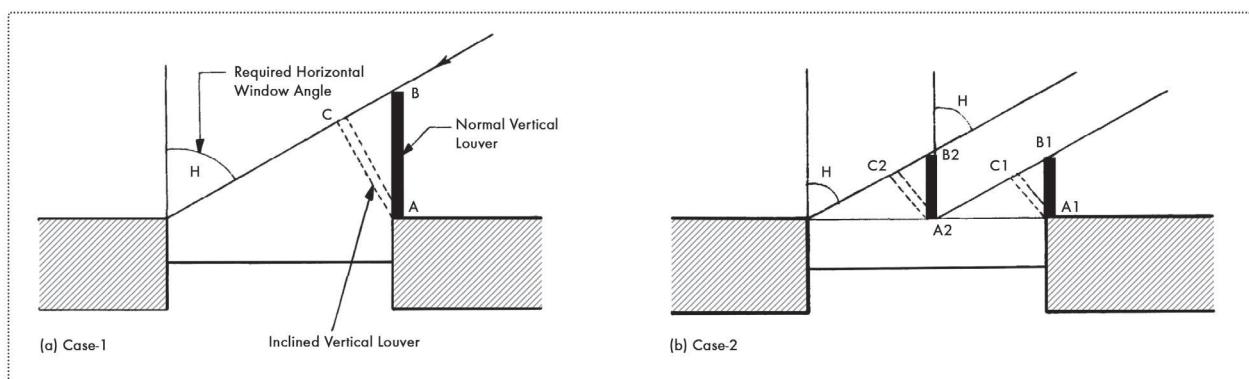

Figure 29: (L) Window plan--one vertical louver (normal/inclined) louver for the whole window, (R) Window split into two-louver lengths also get halved-one louver for each half. [8]

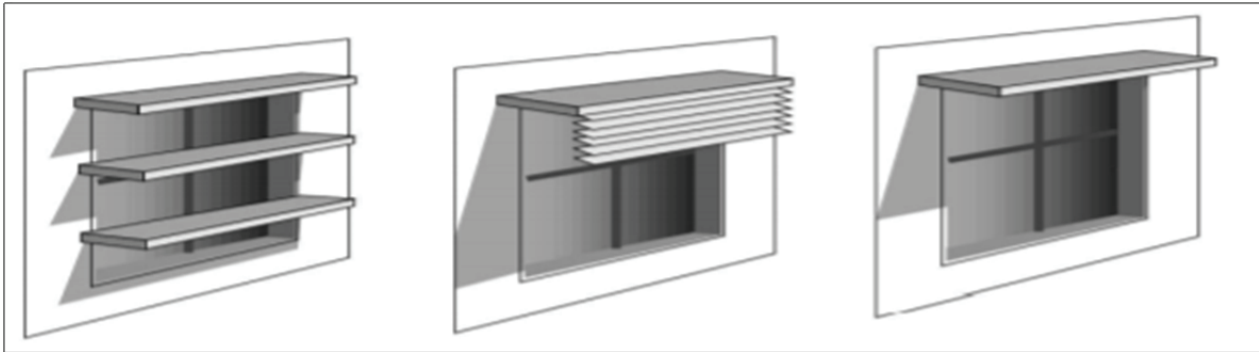

Figure 30: Overhang divided into multiple overhangs [16]

A quick method to calculate the depth of the required dimensions of the desired type of shading device for various facades are presented in **Annexure-2** in Table for both northern and southern region of India. Recommendations for the optimum design are also given in the last column of the tables together with their expected performance as per SP: 41 Handbook on Functional Requirements of Buildings.

Energy Conservation Building Code-2017 suggests a simple method to determine the surrounding obstructions a permanent shading or not by using a sun-path diagram. The surrounding man-made or natural sunlight obstruction should shade the façade for at least 80% of the total time the façade is exposed to direct sun-light on a summer solstice day to be considered as a permanent shading. [11]

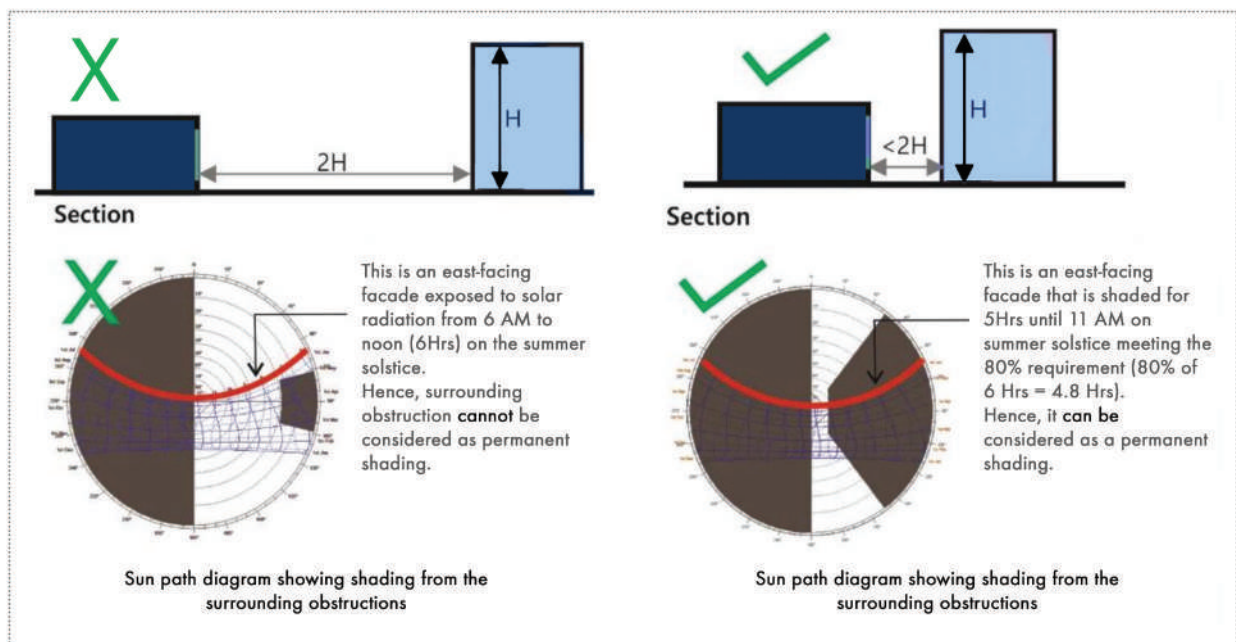

Figure 31: Using sun path for showing compliance for surrounding obstructions [11]

Fenestration Design

With an understanding of daylight availability, its transmission parameters, thumb rules, and daylight performance metrics, one can begin with the designing of an integrated daylight system with a four-phase approach methodology. This four-phase process majorly consists of the implementation of the (a) conceptual phase, (b) design phase (c) construction phase and, (d) commissioning and post occupancy phase [9].

Daylighting planning has different objectives at each stage of the building envelope design:

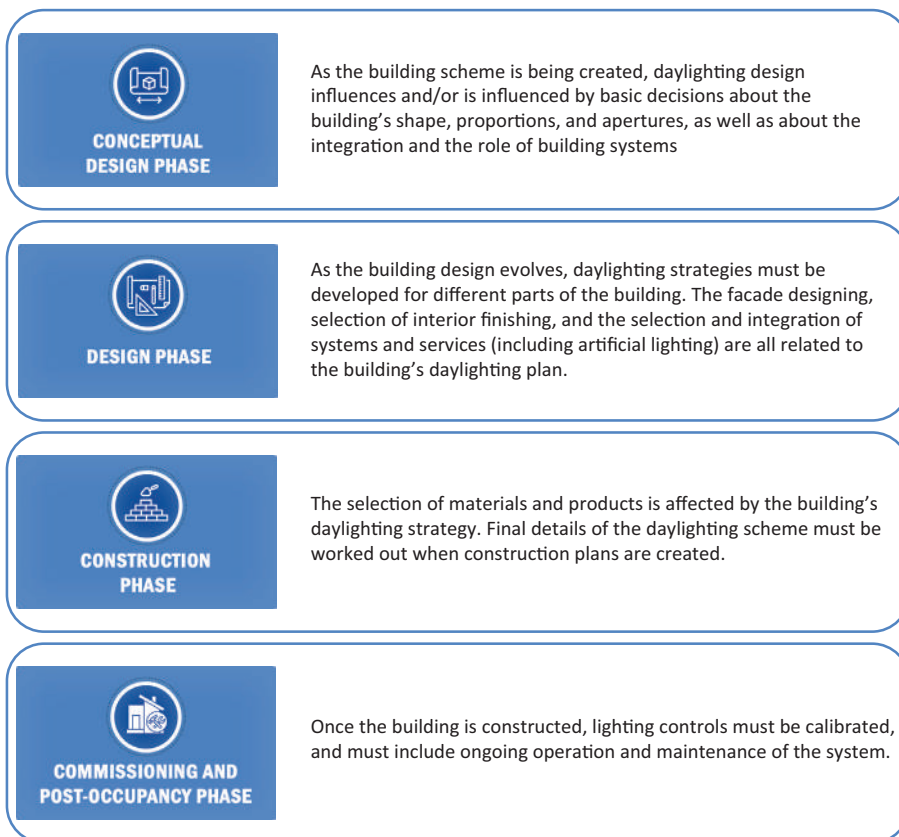
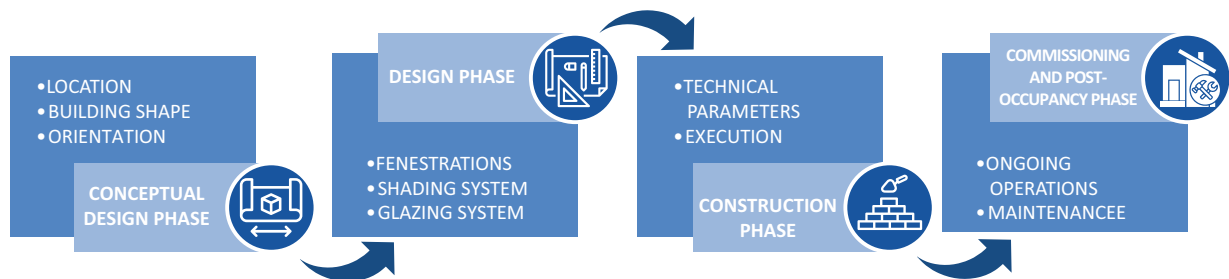

Figure 32: Stages of the building envelope design [9]

To understand this process better a step-by-step methodology for fenestration design is derived by linking the conceptual framework of daylighting with the technical framework simultaneously. The flow chart in Figure 32 shows the conceptual and technical considerations of each step on the right and left side, respectively.

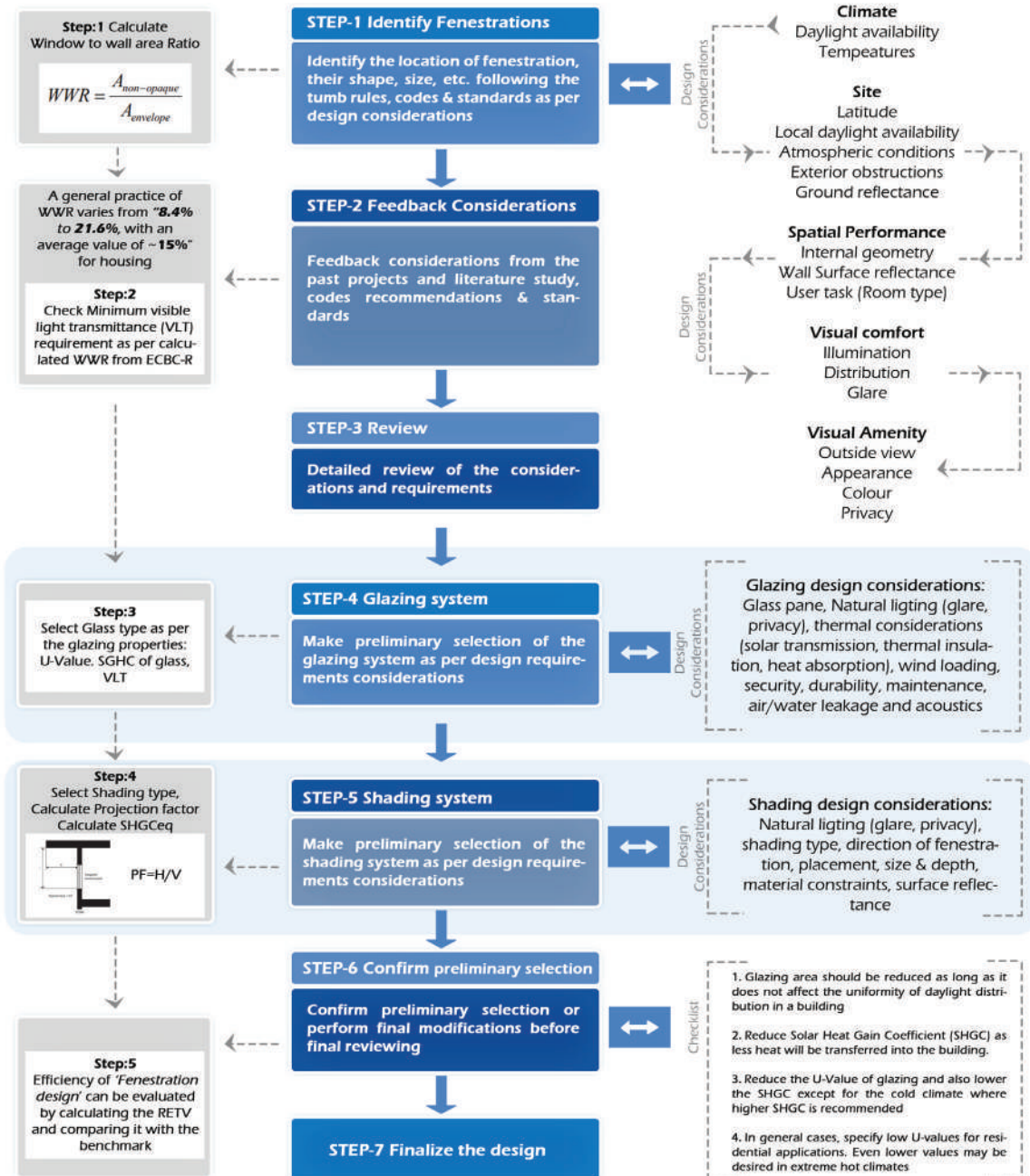

Figure 33: Fenestration design methodology [31] [20] [32] [16] [33]

Step 1: The first step is to 'identify fenestrations' on a building facade by analysing the location, climate conditions, and site characteristics, spatial performance of the building, visual comfort, and amenities of the desired housing space. In technical terms, this is nothing but the WWR of the facade which is the ratio of the area of non-opaque construction to the area of building envelope.

Step 2: The second step is to incorporate the ‘feedback considerations’ from the past projects, literature study, best practices, codes and standards to ascertain the technical values, and benchmarks recommended by the manuals for affordable housing in India that can help in designing the building envelope with an energy-efficient approach. A study was conducted by an ECBC-R team in 2018 during the development of the residential code Eco-Niwas Samhita for India where they evaluated that during the residential project survey, WWR varied from 8.4% to 21.6%, with an average value of ~15% [31]. Such recommendations from the literature help in identifying the desired preliminary WWR% to begin with the conceptual designing phase. Furthermore, openable window-to-floor area ratio (WFR_{op}) is calculated to decide upon the WWR%. As with all rules of thumb, it should only be used as a starting point for a design and later firmed by a skilled designer through computer modelling. This would help in accounting the complexity of the thermal interactions in a building. As a general guide, the total window area should be less than 25% of the total floor area of the house [19].

Step 3: The third step is to do a detailed review of the preliminary design considerations to make sure the WWR% is in line with the site characteristics and housing type.

Step 4: After the preliminary designing and selection of the WWR% from the feedback considerations and analysis, the next step is to identify the ‘glazing system’ for the fenestration design. As discussed in the earlier sections of this document, glazing plays an important role in the transmission of daylight into a building. The selection of glass can be decided based on certain considerations including, type of glass pane, availability of natural light (glare and privacy), durability, maintenance, and acoustic details [32]. A set of affordable glazing options according to the market assessment is listed in Table 1.

Step 5: The next step is to determine the type and size of ‘shading devices’. Generally, a shadow angle protractor is used as an overlay in conjunction with the solar chart. For a given window width, this angle represents the size of the vertical louver on one side edge of the window. The sun is masked by the vertical louver from entering the window as long as the horizontal shadow angle of the sun’s position is greater than the horizontal window angle [16] which is further utilised for the PF and SHGC_{ef} calculations.

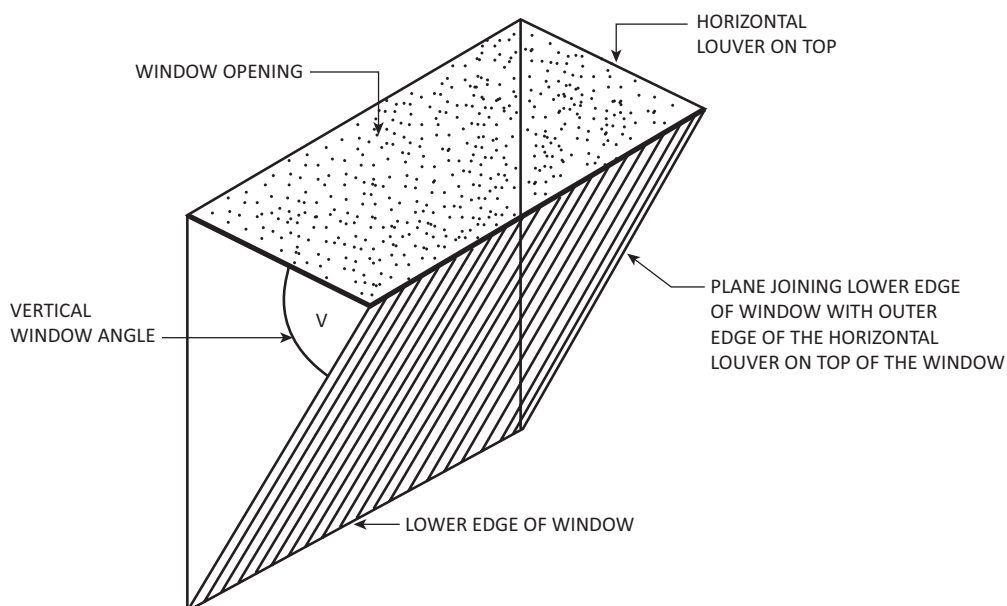

Figure 34: Window angle in a shading device [16]

Furthermore, as mentioned in Table 1, shading devices can be majorly categorized into a two-layer system:

- External shading such as overhangs, louvers, sun breakers, *verandahs*, etc.
- Internal shading such as curtains, blinds, etc.

Step 6: The last step before finalizing the fenestration design is to 'confirm the preliminary selection'. This can be done by first understanding the overall effects of the daylighting parameters and their technical properties at their respective stages. A compiled checklist of these observations is listed as follows:

Checklist:

- Longer axis of the housing should be in East–West direction with larger facade facing North and South.
- Glazing area should be reduced as long as it does not affect the uniformity of daylight distribution in a building.
- Reduce SHGC to enable the transfer of less heat into the building.
- Reduce the U-value of glazing and also lower the SHGC except for the cold climate where higher SHGC is recommended.
- In general cases, specify low U-values for residential applications. Even lower values may be desired in extreme hot climates.

Another method to check the effectiveness of the preliminary selection of the fenestration design is to calculate the residential envelope transmittance value (RETV) of the building. (Check Building: Envelope (B Level) under Parameters section for calculation)

According to ECC-R (2018), RETV for the building envelope (except roof) of four climate zones, namely, composite climate, hot–dry climate, warm–humid climate, and temperate climate shall comply with the maximum RETV of **15 W/m²** [20].

Step-7: After evaluating the RETV value and taking considerations from the checklist, one can finalize the fenestration design which will act as an affordable yet sustainable daylight system solution for affordable housing.

A worked-out example is shown in **Annexure-3**

Conclusion

This 'daylight system for affordable housing in India' guidebook elaborates the importance of integrating daylighting in affordable housing with a detailed understanding of the best practices, benchmarks, codes, and standards. Additionally, it sets as a base for understanding the daylighting parameters, thumb rules, and performance metrics considered for the daylight integration for any building typology. It can be affirmed that daylighting with appropriate electric lighting controls and fenestration design can result in significant energy savings by reducing electric lighting loads and associated cooling loads. Furthermore, it improves the overall attitude, satisfaction, and well-being of the building occupants that account for the psychological benefits and helps in generating the best performing environment delivering the highest quality of light for any visual task. A design checklist is prepared to comprehend the vast information of daylight parameters, metrics, and considerations discussed in this guidebook for designing a daylight system for affordable housing in India. Although, it is beneficial to analyze these considerations through daylight simulations as a next step and implement the optimised design outcome considering the overall building energy performance.

Checklist	Considerations
<ul style="list-style-type: none"> ✓ Guidelines <ul style="list-style-type: none"> ▪ Codes and Standards ▪ Thumb Rules ▪ Best Practices ✓ Building Energy Use ✓ Economic constraints ✓ Visual comfort and performance <ul style="list-style-type: none"> ▪ Illumination ▪ Distribution ▪ Glare ✓ Visual Amenity <ul style="list-style-type: none"> ▪ Outside view ▪ Appearance ▪ Colour ▪ Privacy ▪ Social Behaviour ✓ Task <ul style="list-style-type: none"> ▪ User ▪ Room type ▪ Occupancy schedule 	<ul style="list-style-type: none"> ✓ Climate <ul style="list-style-type: none"> ▪ Daylight availability ▪ Temperatures ✓ Site <ul style="list-style-type: none"> ▪ Latitude ▪ Local daylight availability ▪ Atmospheric conditions ▪ Exterior obstructions ▪ Ground reflectance ✓ Room <ul style="list-style-type: none"> ▪ Internal geometry ▪ Surface reflectance ✓ Fenestration <ul style="list-style-type: none"> ▪ Size ▪ Placement ▪ Orientation ✓ Screening and shading systems <ul style="list-style-type: none"> ▪ Size ▪ Orientation ▪ Placement ▪ VLT ▪ U-Value ▪ SHGC

Annexure 1

Table 13: External shading factor for overhang for Latitude $\geq 23.5^\circ\text{N}$

LAT $\geq 23.5^\circ\text{N}$								
External Shading Factor for Overhang for LAT $\geq 23.5^\circ\text{N}$								
PF _{overhang}	N	NE	E	SE	S	SW	W	NW
0.1	1	1	1	1	1	1	1	1
0.19	0.955	0.93	0.922	0.906	0.881	0.905	0.922	0.93
0.29	0.922	0.876	0.855	0.824	0.789	0.823	0.583	0.875
0.39	0.897	0.834	0.796	0.755	0.719	0.753	0.794	0.834
0.49	0.877	0.803	0.745	0.697	0.665	0.695	0.743	0.802
0.59	0.86	0.779	0.702	0.652	0.626	0.65	0.7	0.778
0.69	0.846	0.761	0.666	0.617	0.598	0.614	0.663	0.76
0.79	0.834	0.747	0.635	0.59	0.58	0.587	0.632	0.746
0.89	0.825	0.737	0.609	0.569	0.569	0.566	0.606	0.736
0.99	0.817	0.729	0.587	0.554	0.563	0.551	0.585	0.728
≥ 1	0.81	0.722	0.569	0.542	0.559	0.539	0.566	0.721

PF: Projection factor; LAT: Latitude

Table 14: External shading factor for overhang for Latitude $< 23.5^\circ\text{N}$

LAT $< 23.5^\circ\text{N}$								
External Shading Factor for Overhang (ESF _{overhang}) for LAT $< 23.5^\circ\text{N}$								
PF _{overhang}	N	NE	E	SE	S	SW	W	NW
0.1	1	1	1	1	1	1	1	1
0.19	0.931	0.924	0.922	0.91	0.896	0.91	0.922	0.924
0.29	0.888	0.864	0.855	0.834	0.816	0.834	0.584	0.864
0.39	0.86	0.818	0.797	0.771	0.754	0.771	0.796	0.818
0.49	0.838	0.782	0.747	0.721	0.708	0.72	0.746	0.782
0.59	0.82	0.755	0.705	0.682	0.675	0.681	0.705	0.755
0.69	0.806	0.734	0.67	0.651	0.653	0.651	0.67	0.734
0.79	0.793	0.718	0.641	0.628	0.638	0.627	0.64	0.717
0.89	0.783	0.706	0.616	0.61	0.628	0.609	0.615	0.705
0.99	0.775	0.696	0.596	0.596	0.621	0.596	0.535	0.695
≥ 1	0.768	0.688	0.579	0.585	0.616	0.585	0.578	0.688

PF: Projection factor; LAT: Latitude

Table 15: External shading factor for side fin-right for Latitude $\geq 23.5^\circ\text{N}$

LAT $\geq 23.5^\circ\text{N}$								
External Shading Factor for Side Fin-Right (ESF_{right}) for LAT $\geq 23.5^\circ\text{N}$								
PF_{sidefinR}	N	NE	E	SE	S	SW	W	NW
0.1	1	1	1	1	1	1	1	1
0.19	0.968	0.942	0.972	0.982	0.961	0.965	0.988	0.985
0.29	0.943	0.894	0.949	0.968	0.933	0.934	0.977	0.972
0.39	0.924	0.855	0.931	0.957	0.912	0.907	0.968	0.961
0.49	0.911	0.824	0.917	0.95	0.898	0.884	0.96	0.953
0.59	0.899	0.798	0.905	0.944	0.887	0.865	0.654	0.945
0.69	0.89	0.777	0.895	0.939	0.88	0.849	0.648	0.939
0.79	0.883	0.762	0.887	0.936	0.875	0.837	0.643	0.934
0.89	0.877	0.75	0.881	0.933	0.872	0.827	0.939	0.93
0.99	0.871	0.739	0.875	0.93	0.868	0.819	0.935	0.926
≥ 1	0.865	0.731	0.87	0.927	0.865	0.812	0.932	0.922

PF: Projection factor; LAT: Latitude

Table 16: External shading factor for side fin-right for Latitude $< 23.5^\circ\text{N}$

LAT $< 23.5^\circ\text{N}$								
External Shading Factor for Side Fin-Right (ESF_{right}) for LAT $< 23.5^\circ\text{N}$								
PF_{sidefinR}	N	NE	E	SE	S	SW	W	NW
0.1	1	1	1	1	1	1	1	1
0.19	0.962	0.948	0.975	0.982	0.962	0.959	0.984	0.984
0.29	0.934	0.904	0.954	0.968	0.932	0.924	0.97	0.97
0.39	0.913	0.868	0.937	0.957	0.911	0.894	0.958	0.959
0.49	0.9	0.84	0.924	0.949	0.896	0.87	0.949	0.95
0.59	0.888	0.816	0.92	0.942	0.885	0.849	0.94	0.942
0.69	0.879	0.797	0.903	0.936	0.877	0.832	0.933	0.936
0.79	0.872	0.782	0.896	0.932	0.872	0.82	0.927	0.931
0.89	0.866	0.77	0.889	0.929	0.867	0.81	0.922	0.927
0.99	0.86	0.76	0.884	0.925	0.863	0.801	0.917	0.923
≥ 1	0.855	0.752	0.878	0.922	0.859	0.794	0.913	0.919

PF: Projection factor; LAT: Latitude

Table 17: External shading factor for side fin-left for Latitude $\geq 23.5^\circ\text{N}$

LAT $\geq 23.5^\circ\text{N}$								
External Shading Factor for Side Fin-Left (ESF_{left}) for LAT $\geq 23.5^\circ\text{N}$								
PF_{sidefinL}	N	NE	E	SE	S	SW	W	NW
0.1	1	1	1	1	1	1	1	1
0.19	0.968	0.985	0.988	0.965	0.961	0.982	0.972	0.942
0.29	0.943	0.972	0.977	0.933	0.932	0.967	0.949	0.895
0.39	0.925	0.961	0.968	0.906	0.911	0.957	0.931	0.857
0.49	0.912	0.953	0.961	0.883	0.897	0.949	0.916	0.826
0.59	0.9	0.946	0.954	0.863	0.886	0.943	0.904	0.801
0.69	0.89	0.939	0.948	0.846	0.879	0.938	0.895	0.781
0.79	0.884	0.935	0.944	0.834	0.874	0.935	0.887	0.766
0.89	0.877	0.931	0.94	0.824	0.871	0.932	0.881	0.754
0.99	0.871	0.927	0.936	0.815	0.867	0.929	0.875	0.744
≥ 1	0.866	0.923	0.932	0.808	0.864	0.927	0.87	0.736

PF: Projection factor; LAT: Latitude

Figure 18: External shading factor for side fin-left for Latitude $< 23.5^\circ\text{N}$

LAT $< 23.5^\circ\text{N}$								
External Shading Factor for Side Fin-Left (ESF_{left}) for LAT $< 23.5^\circ\text{N}$								
PF_{sidefinL}	N	NE	E	SE	S	SW	W	NW
0.1	1	1	1	1	1	1	1	1
0.19	0.962	0.984	0.984	0.959	0.962	0.982	0.975	0.948
0.29	0.933	0.97	0.97	0.924	0.932	0.968	0.954	0.904
0.39	0.912	0.959	0.958	0.895	0.911	0.956	0.937	0.868
0.49	0.899	0.95	0.949	0.87	0.896	0.948	0.924	0.84
0.59	0.887	0.942	0.941	0.849	0.885	0.942	0.913	0.816
0.69	0.878	0.935	0.933	0.833	0.877	0.936	0.903	0.797
0.79	0.871	0.931	0.928	0.82	0.871	0.932	0.896	0.783
0.89	0.865	0.926	0.923	0.81	0.867	0.928	0.89	0.771
0.99	0.859	0.922	0.918	0.801	0.869	0.925	0.884	0.761
≥ 1	0.854	0.919	0.913	0.794	0.859	0.922	0.879	0.752

PF: Projection factor; LAT: Latitude

Table 19: Coefficients (a, b, and c) for RETV formula for cooling dominated climatic zones [20]

Climate zone	a	b	c
Composite	6.06	1.85	68.99
Hot-Dry	6.06	1.85	68.99
Warm-Humid	5.15	1.31	65.21
Temperate	3.38	0.37	63.69

Table 20: Orientation factor (ω) for different orientations [20]

Orientation	Orientation factor (ω)	
	Latitudes $\geq 23.5^\circ$ N	Latitudes $< 23.5^\circ$ N
North (337.6°–22.5°)	0.550	0.659
North-east (22.6°–67.5°)	0.829	0.906
East (67.6°–112.5°)	1.155	1.155
South-east (112.6°–157.5°)	1.211	1.125
South (157.6°–202.5°)	1.089	0.966
South-west (202.6°–247.5°)	1.202	1.124
West (247.6°–292.5°)	1.143	1.156
North-west (292.6°–337.5°)	0.821	0.908

Annexure 2

Table 21: Spacing distances between vertical or horizontal members of louver systems (Northern region)

S. No.	Direction	Type of Louver	Spacing Between Vertical or Horizontal Angle of Inclination					Direction of Inclination	Performance	Recommended
			B=0°	B=15°	B=30°	B=45°	B=60°			
A	North Case-1	V	3.73 P	Inclining	Not desirable			---	Cuts-off after 7 am during June and completely in other months	For air-conditioned buildings.
	North Case-2	V	2.15 P	---	do		---	---	Cuts-off completely at all times	do
B	South Case1	H	1.73 P	2 P	2.3 P	2.73 P	2.46P	Downwards	Completely cuts off summer sun and allows winter sun indoors	Type H (B = 0)
C	East/West Case-1	V	Inclining up to 30°		Not desirable	0.73 P	1.46 P	Towards north away from normal	Cuts-off both summer and winter sun	Type C Combination of types V (B= 30°) and H (B = 0°)
	East/West Case-2	H	0.27 P	0.54 P	0.85 P	1.27 P	2 P	Downwards	Cuts-off only after 7 am in summer and winter	
	East/West Case-3	C (V)	Inclining up to 15° not desirable		0.21 P	0.64 P	1.37 P	Away from normal towards	Completely cuts-off only summer sun but allows winter sun to come partially	
		C (H)	0.84 P	1.11 P	1.42 P	1.84 P	2.57 P	Downwards	----	
D	North-East/ North West Case-1	V	0.36 P	0.63 P	0.94 P	1.36 P	2.1 P	Towards north away from normal	Winter sun negligible on this facade and summer sun cut-off completely	Type V (B = 30°)
	North-East/ North West Case-2	H	0.47 P	0.74 P	1.05 P	1.47 P	2.2 P	Downwards	Cuts-off only after 7am	----
E	South-East/ South-West Case 1	C (V)	0.36 P	0.63 P	0.94 P	1.36 P	2.1 P	Southwards away from normal	Completely cuts-off all summer sun and allows winter morning sun partially indoors	Type C Combination of types V (B = 30°) and H (B = 0°)
		C (H)	0.84 P	1.1 P	1.42 P	1.84 P	2.57 P	Downwards		

Note: In Type C above, any combination of the angles of inclination of vertical and horizontal members can be made.

Note:

P- It denotes the outward projection of the louver system perpendicular to the wall. All other dimensions are given in terms of P only.

B - It is the angle of inclination of the louver away from the normal to the wall. A value of B = 0 signifies a vertical or horizontal louver normal to the wall.

Table 22: Spacing distances between vertical or horizontal members of louver systems (Southern region)

S. No.	Direction	Type of Louver	Spacing Between Vertical or Horizontal Angle of Inclination					Direction of Inclination	Performance	Recommended
			B=0°	B=15°	B=30°	B=45°	B=60°			
A	North Case-1	V	2.75 P	Inclining	Not desirable			---	Cuts-off after 7 am during June and completely in other months	For air-conditioned buildings.
	North Case-2	V	2.15 P	---	---	---	---	---	Cuts-off completely at all times	For air-conditioned buildings
B	South Case1	H	2.75 P	3 P	3.33 P	3.75 P	4.5 P	Downwards	Cuts-off all summer sun after 15 March to 30 September	Type H (B = 0)
C	East/West Case-1	V	Inclining up to 30° not desirable			0.53 P	1.27 P	Inclined towards north way from the normal	Cuts-off both summer and winter sun	Type C Combination of types V (B = 30°) and H (B = 0°)
	East/West Case-2	H	0.27 P	0.54 P	0.85 P	1.27 P	2 P	Downwards	Cuts-off only after 7 am in summer and winter	
	East/West Case-3	C (V)	Inclining up to 15° not desirable			0.31 P	0.73 P	1.46 P	Inclined towards south away from normal	
C (H)		0.84 P	1.11 P	1.42 P	1.84 P	2.57 P	Downwards			
D	North-East/ North West Case-1	V	0.36 P	0.63 P	0.94 P	1.36 P	2.1 P	Towards north away from normal	---	---
	North-East/ North West Case-2	H	0.36 P	0.63 P	0.94 P	1.36 P	2.1 P	Downwards	Winter sun negligible on this facade and summer sun is completely cut-off Cuts-off only after 7 am	Type V (B = 30°)
E	South-East/ South-West Case 1	C (V)	0.58 P	0.85 P	1.15 P	1.58 P	2.31 P	Southwards away from normal	Completely cuts-off all summer sun and allows winter morning sun partially indoors	Type C Combination of types V (B = 30°) and H (B = 0°)
		C (H)	P	1.27 P	1.58 P	2 P	3.73 P	Downwards		

Note: In Type C above, any combination of the angles of inclination of vertical and horizontal members can be made.

Note:

P- It denotes the outward projection of the louver system perpendicular to the wall. All other dimensions are given in terms of P only.

B - It is the angle of inclination of the louver away from the normal to the wall. A value of B = 0 signifies a vertical or horizontal louver normal to the wall.

Annexure 3

The daylighting calculation explained in 'Fenestration Design' section is demonstrated below with an example. For explaining the process, a study published by (Bhanware, et al., 2019) has been referred for defining building geometry and plan. The location considered for the example is Delhi (specified for the purpose of identifying latitude and longitude only)

STEP-1

A building mass of dimension 10mX8m has been considered for designing a G+1 2BHK affordable housing unit. The finished height of each unit assumed is 3m.

To identify the placement of adjacent blocks, without hindering the provision of daylight, follow, **the 'Atrium Rule' (Page 32). It defines that the height of the building <math>< 2.5 \times \text{width}</math>.**

Therefore, considering G+1 building of a total 6m height, the distance between two adjacent blocks should be above 2.4m. A width of 2.5m has been considered for placing adjacent blocks.

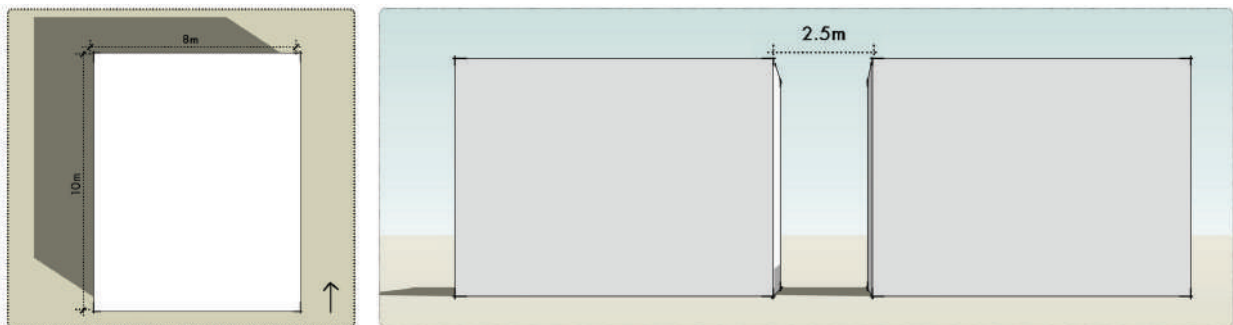

Figure 35: Dimensions of one block and distance between two blocks by applying atrium thumb rule.

The cluster of four-dwelling units is suggested below considering the above rule.

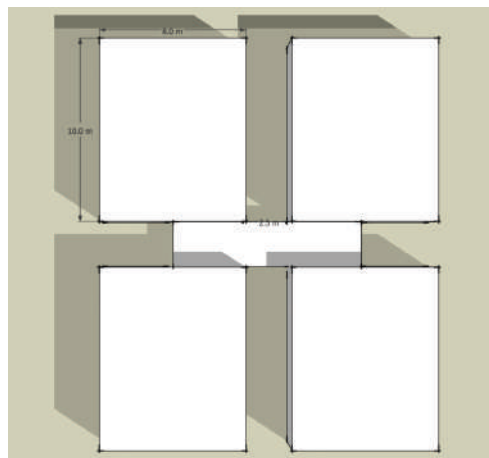
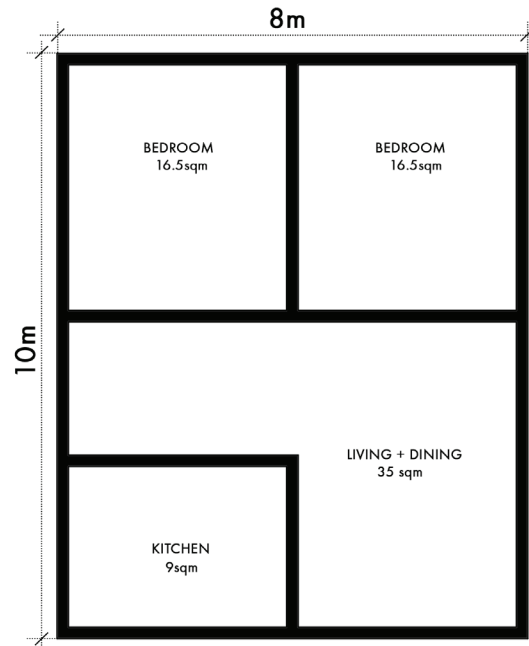

Figure 36: Cluster of four-dwelling units

STEP-2

Moving to the dwelling unit level, the following layout is proposed.



Source: [31]

The example further details out the window placement for daylighting design for dwelling units with bedrooms facing North & South.

As per the rule, **the depth of daylit zone is typically 1.5–2 times the window head height. If a space does not require the use of a shading device, the ratio range can increase up to 2.5-times.**

Therefore, for a 4mX4m bedroom to be 100 percent day-lit, the window head height is calculated by the following:
Window head height = Depth of Room/2 = 2m (including Sill height = 0.9m) = ~2.1m

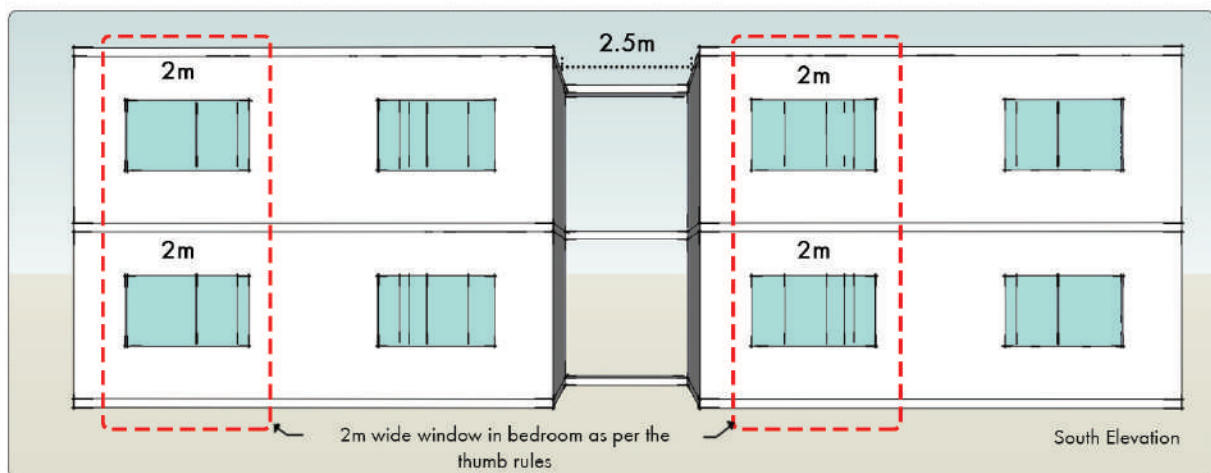

Figure 37: Case-1 South elevation with 2m wide windows

For calculating the width, we follow **the daylit area extends 'a horizontal dimension equal to the width of the window plus either 1 m (3.3 ft) on each side of the opening, the distance to the opaque partition, or one-half the distance to an adjacent skylight or window, whichever is least'.**

Width = Width of the room - (1m offset on each side) = 4m - 2m = 2m

Similarly, the window width and height can be defined for other living spaces as well.

STEP-3

The WWR of the North and South elevations of the demonstrated example is the following:

$$WWR = [(2m \times 2.1m) \times 4] / (10m \times 8m) = 0.21$$

The VLT specification could be finalized through the table 6.

As the WWR lies between 0-0.3, the minimum VLT prescribed is 0.27

Design flexibility allows us to create multiple layout combinations. Following is an example of one such iteration in the layout leading to alterations in window orientation and position.

STEP-4

Shading design is the most crucial aspect when it comes to designing a window. The following example is for windows sized in Plan - A.

The dimension of the window is; height=1.5m, width=2m

As per the specified rules, no requirement for a horizontal projection is defined for North orientation. However, for the South facing window, it specifies:

Width of the window = 1.73 * Depth of the Horizontal Shading (H)

Depth of the Horizontal shading = 200cms / 1.73 = ~115cms or 1.2m

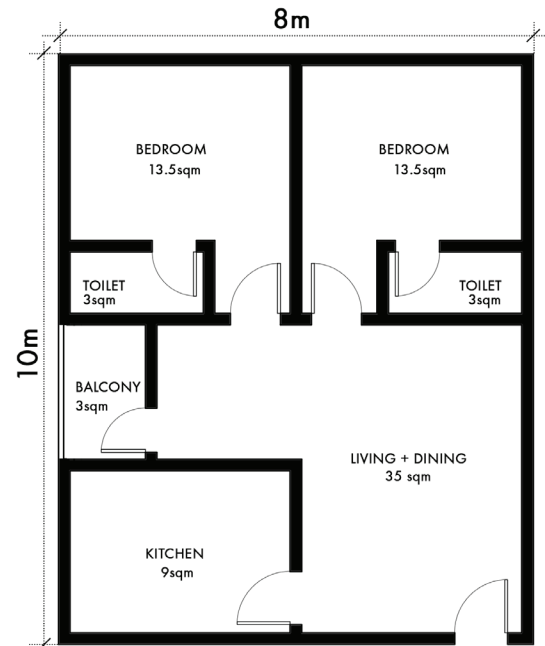

Figure 38: Plan A designed from the base case

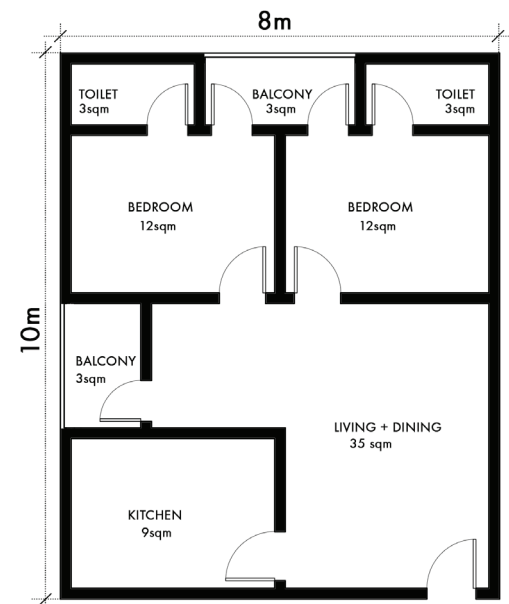

Figure 39: Plan B option

STEP-5

This depth of the projection seems equivalent to the width of a balcony, therefore, it is now essential to revisit the window design and placement in STEP – 2.

Reducing the width of the window is likely to reduce the depth of the overhang. Therefore, instead of designing a single window of 2m, 2 windows of 1m width each can be specified.

Now, the depth of the horizontal shading = $100\text{cms}/1.73 = \sim 60\text{cms}$ or 0.6m.

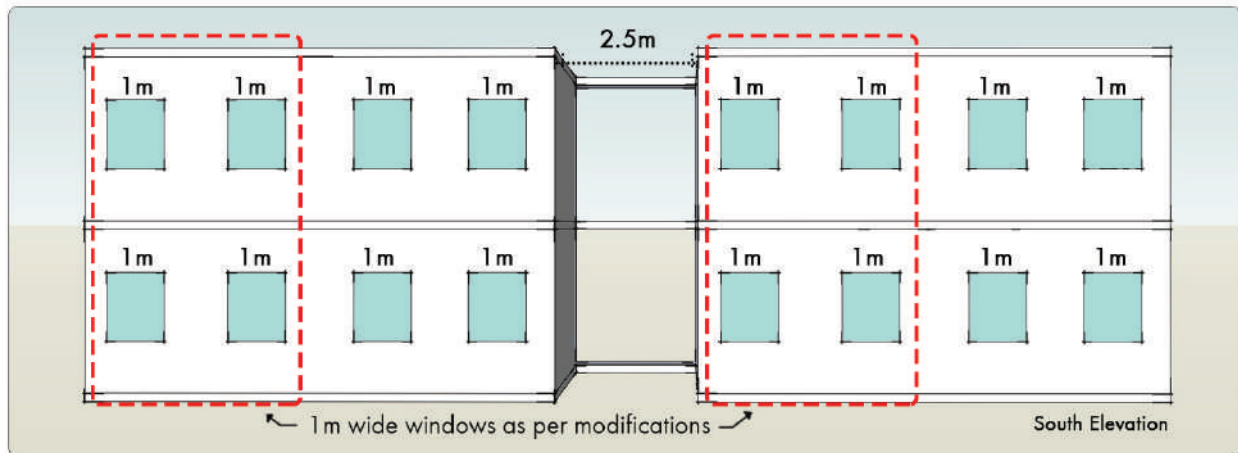

Figure 40: Case-2 South elevation with 1m wide each

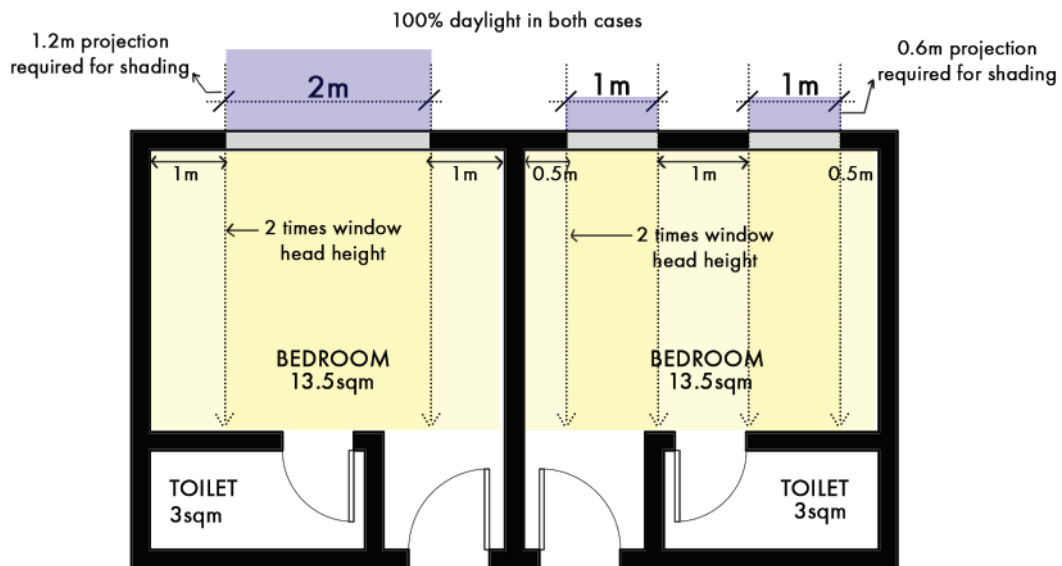

Figure 41: Comparison between case-1 windows and case-2 windows

Similarly, for Plan – B, the rules specify applying vertical fins or horizontal fins or both, which can be designed similar to the above example.

References

- [1] Worldometer.info. [Online]. Available: <https://www.worldometers.info/>.
- [2] M. o. H. a. U. Affairs, "Handbook of Urban Statics," Govt. of India Press, Minto Road, New Delhi, 2016.
- [3] N. C. o. Population, "Population projectios for India and states 2011-2036," Ministry of Health & Family Welfare, New Delhi, 2019.
- [4] Ministry of Housing & Urban Poverty Alleviation, Government of India, "Annual Report," New Delhi, 2014-15.
- [5] C. E. Authority, "Annual Report," Ministry of Power, New Delhi, India, 2019.
- [6] C. F. Reinhart, *Daylighting Handbook: Fundamentals, designing with the sun*, Massachusetts, USA: Building Tecnology Press, 2014.
- [7] S. N. F. S. H. a. Z. Y. H. Harith, "The Performance Of daylight through various Type of Fenestration in Residential Building," in *ASEAN conference on Environment-Behaviour studies, bandun Hotel, Selangor, Malaysia*, 2011.
- [8] "Handbook Of Functional Requirements Of Buildings," Bureau of Indian Standards, New Delhi, India, 1995.
- [9] E. A. IEA, "Daylight in buildings," Lawrence Berkeley National Laboratory, Berkeley, 2000.
- [10] S. S. Alastair Robinson, "Tips for Daylighting with windows," Lawrence Berkeley National Laboratory, Berkeley, Calafornia , 2013.
- [11] "ECBC- User Guide," Bureau of Energy Efficiency, New Delhi, India, 2017.
- [12] T. D. a. Y. C. P. Dogan and Park, "A new framework for residential daylight performace evaluation," Environmental Systems Lab, Cornell, Ithaca, New York, USA, 2017.
- [13] J. Mardaljevic, "Daylight Simulation: Validation, Sky Models and Daylight Coefficients," Institute of Energy and Sustainable Development, De Montfort University, Leicester, 1999.
- [14] R. srikonda, "Window Sizing for Daylighting for Non-Airconditioned Buildings in Andhra Pradesh, India," *Journal of Architecutal Engineering Technology*, 2018.
- [15] I. M. E. a. A. B. Ihab and Ayesha, "Veiled Facades: Impacts of Patterned-Mass Shades on Building Energy Savings, Daylighting Autonomy, and Glare Management in Three Different Climate Zones," in *International Building Performance Simulation Association Conference*, Sanfransico, 2017.
- [16] "National Building Code Of India," Bureau Of Indian Standards, New Delhi, India, 2016.
- [17] D. A. Marsh, "AndrewMarsh.com," [Online]. Available: <http://andrewmarsh.com/>.
- [18] A. S. B. Design, Autodesk, 2018. [Online]. Available: <https://knowledge.autodesk.com/search-result/caas/simplecontent/content/aperture-placement-area.html>.
- [19] S. N.L.NIK Ibrahim, "Daylighting design rules of thumb," in *Sustainable buildings south east Asia*, Malaysia, 2005.
- [20] M. O. P. Eco Niwas Samitha, "ECBC- Residential," Bureau Of Energy and Efficiency, New Delhi, India, 2018.
- [21] "Glazing Society of India," [Online]. Available: <https://www.glazingsociety.com/index.php>.

- [22] Indo-Swiss Building Energy Efficiency Project, "External Movable Shading Systems (EMSYS) Brochure".
- [23] Bureau of Energy Efficiency (BEE), USAID, Market Integration and Transformation Program for Energy Efficiency (MAITREE), "Net zero Energy Buildings," [Online]. Available: <https://nzeb.in/>.
- [24] A. S. d. Electricciens, "Éclairage intérieur par la lumière du jour," Swiss Norm SN 418911, Zurich, 1989.
- [25] J. M. Z. R. Christoph F. Reinhart, "Dynamic daylight performance metrics for sustainable building design," *LEUKOS*, vol. 3, no. 1, 2006.
- [26] M. L. Mark Frankel, "Daylight Pattern Guide," New Buildings Institute (NBI), [Online]. Available: <https://patternguide.advancedbuildings.net/>.
- [27] "Illuminating Engineering Society Annual Conference 2013," in *Illuminating Engineering Society of North America (IESNA)*, Huntington Beach, California, USA., 2013.
- [28] M. Á. C. S. D. & J. F.-A. Ignacio Acosta, "Minimum Daylight Autonomy: A New Concept to Link Daylight Dynamic Metrics with Daylight Factors," *LEUKOS - The Journal of the Illuminating Engineering Society*, Vols. Volume-15, no. 4, pp. 251-269, 2019.
- [29] J. M. A. Nabil, "Useful daylight illuminance: A new paradigm for assessing daylight in buildings," *Lighting Research and Technology*, vol. 37, no. 1, pp. 1-27, 2005.
- [30] F. Moore, *Concepts and Practice of Architectural Daylighting*, New York : Van Nostrand Reinhold: John Wiley & Sons Inc (April 1, 1991), 1993.
- [31] P. J. S. M. A. L. S. C. V. P. K. S. R. S. M. S. D. A. N. A. S. A. S. Prashant Kumar Bhanware, "Development of RETV (Residential Envelope Transmittance Value) Formula for Cooling Dominated Climates of India for the Eco-Niwas Samhita 2018 (Indo-Swiss Building EnergyEfficiency Project)," in *6th IBPSA Conference*, Rome, Italy, 2018.
- [32] *One day national workshop on National Building Code of India, 2016, Glass and glazing aspects*, Glazing Society of India, 2016.
- [33] "Energy Performance Ratings for Windows, Doors, and Skylights," U.S. department of Energy, [Online]. Available: energy.gov.
- [34] T. E. a. R. Institute, "Technology Lever for Green housing scale up India," IFC-Internation Finanace Corporation World Bank Group , New Delhi, 2019.
- [35] European standard EN-12464-1, Light and lighting - Lighting of work places - Part 1: Indoor work places, June 2011.
- [36] R. Bhatia, Interviewee, *Window-Door frames*. [Interview]. May 2019.
- [37] S. K. R, "Comparison of Windows made with different type of Materials A case study," National Institute of Construction Management and Research, Hyderabad, 2010.

The Mahindra-TERI Centre of Excellence (MTCoE) is a joint research initiative of Mahindra Lifespaces (MLDL) and The Energy and Resources Institute (TERI). It focuses on developing science-based solutions for India's future built environment, with a view to reduce the energy footprint of the real estate industry.

The overall scope of the project includes standardization and measurement of building material, thermal and visual comfort study, development of performance standard matrices, guidelines and numerical toolkits and water related activity for sustainable water use in habitats.

The activities related to the sustainable use of water in habitats, includes both macro and micro level analysis in terms of water efficiency, conservation and management within a premise by end users in Indian cities. The study identifies potential risks associated with water sources, governance, infrastructure and demand & supply and provide recommendations to combat those risks.

MTCoE is located at TERI Gram, Gual Pahari, Gurugram, Faridabad, Haryana.