



# Mobile Air Conditioning (MAC)

A technology landscape, challenges and opportunities  
for sustainable cooling

Shanmuganathan K • Manjeet Singh

© **COPYRIGHT** The material in this publication is copyrighted. Content from this paper may be used for non-commercial purposes, provided it is attributed to the source. Enquiries concerning reproduction should be sent to the address: The Energy and Resources Institute (TERI) Darbari Seth Block, India Habitat Centre, Lodhi Road, New Delhi – 110 003, India

### **Authors**

Mr. Shanmuganathan K, Associate Fellow and Mr. Manjeet Singh, Associate Fellow, Centre for Global Environment Research, The Energy and Resources Institute (TERI)

### **Reviewers**

Mr. I V Rao, Senior Visiting Fellow, Transport & Urban Governance, TERI

Mr. Karan Mangotra, Associate Director, Earth Sciences and Climate Change, TERI (Now with UN Environment Programme)

### **Acknowledgements**

We are grateful to Professor R Saravanan, Department of Refrigeration and Air Conditioning, College of Engineering-Guindy, Anna University, Chennai; Mr. Somnath Sen, Head – Technical Centre, Subros Ltd.; Dr. Nitin Karwa, Technical Leader – Stationary Refrigeration, Honeywell India Technology Center, Gurgaon; Mr. Pramod Kumar, Asst. General Manager, Design & Development, Calsonic Kansei Motherson Auto Products Pvt. Ltd.; Mr. Sridhar Chidambaram, Regional Manager, Advanced Engineering Group – Engineering Services, Infosys, Bangalore for sharing their valuable insights and support through course of the study. We would like to extend our sincere thanks to Mr. I V Rao, Senior Visiting Fellow, TERI for his relentless support and guidance throughout our study.

### **Editorial and Design Team**

Sushmita Ghosh, Senior Editor, TERI; Santosh Gautam, Senior Visualizer, TERI

### **Supported by**

This work was supported by Children's Investment Fund Foundation (CIFF) under the initiative SHEETAL: Alliance for Sustainable Habitat, Energy Efficiency and Thermal Comfort for All – working towards the opportunity for strategic actions to put forward the sustainable cooling agenda in India. TERI is grateful to CIFF for their support.

### **Disclaimer**

The brief is prepared by The Energy and Resources Institute (TERI) after carefully analysing and processing the data and the information collected from primary and secondary sources. All opinions expressed, as well as omissions and eventual errors are the responsibility of the author alone.

### **For more information**

Centre of Global Environment Research, TERI, Darbari Seth Block, IHC Complex, Lodhi Road, New Delhi 110 003, India | Tel.: +91 11 2468 2100 or 2468 2111 | Fax: +91 11 2468 2144 or 2468 2145 Email: [pmc@teri.res.in](mailto:pmc@teri.res.in) | Web: [www.teriin.org](http://www.teriin.org)



# CONTENTS

Abbreviations and acronyms .....	4
Introduction .....	5
History of Mobile Air Conditioning.....	7
Landscape of India’s Mobile Air Conditioning .....	7
Mobile Air Conditioning – An Overview .....	8
Mobile Air Conditioning – Process Description .....	9
Technology Landscaping.....	11
Refrigerant – The Vital Fluid .....	12
Opportunities for Efficient MAC Operation.....	14
Discussions and Ways Forward .....	15
References.....	17

## ABBREVIATIONS AND ACRONYMS

A/C	Air conditioning
ASHRAE	American Society of Heating, Refrigerating and Air-Conditioning Engineers
BS	Bharat Stage
cc	Cubic centimeter
CFC	Chlorofluorocarbon
CO <sub>2</sub>	Carbon dioxide
COP	Coefficient of performance
EV	Electric vehicles
FDC	Fixed Displacement Compressors
GWP	Global Warming Potential
HEV	Hybrid electric vehicles
HVAC	Heating, ventilation, and air conditioning
ICAP	India Cooling Action Plan
kg	kilogram
kW	kilowatt
MAC	Mobile air conditioning
MP	Montreal Protocol
NREL	National Renewable Energy Laboratory
ODP	Ozone depleting potential
ODS	Ozone depleting substances
OT-AD	Orifice Tube – Accumulator Dryer
SIAM	Society of Indian Automobile Manufacturers
SL-MAC	Secondary Loop Mobile Air Conditioning
TERI	The Energy and Resources Institute
TXV-RD	Thermostatic expansion valve – receiver dryer
VDC	Variable Displacement Compressors
$\eta_v$	Volumetric Efficiency



# INTRODUCTION

Today, we drive our automobiles with more controlled climatic conditions and comfort levels that are provided by the Mobile Air Conditioning (MAC), commonly known as car or vehicle A/C system. With the unprecedented growth of the automobile sector and the prevailing hot and humid climatic conditions, the MAC system entails worthy of global attention due to its significant energy consumption, increasing fuel costs, refrigerant usage, and its associated greenhouse gas (GHG) emissions. Cooling in the transport sector currently accounts for about 31% of total GHG emissions, despite all cooling applications consuming only 25% of the energy used. Concentrating to the environmental effects associated with the cooling sector, on January 1, 2019, the Kigali Amendment to the Montreal Protocol, which aims for the phase-down of hydrofluorocarbons (HFCs) production and consumption, became effective after being ratified by 65 countries. The initiative envisages to avoid up to 0.4 °C of global warming by the end of this century, if the reduction of more than 80% of HFCs by 2047 is achieved over the next three decades [1]. The paper summarizes the landscape of MAC system, with its genesis, principle of operations, nature to Indian context, and technology status. The paper also presents key perspectives pertaining to MAC from the Indian Cooling Action Plan (ICAP), India's strategic action plan on cooling over the next 20 years. A comprehensive representation of technology status, opportunities and future developments with MAC system, along with refrigerant landscape and its transition prospects and challenges are outlined for policy practitioners, technology experts, and relevant stakeholders in strategizing the measures towards sustainable cooling.





# HISTORY OF MOBILE AIR CONDITIONING

The early decade of 19th century laid the foundation of the modern air conditioning systems when Willis Carrier, a junior engineer, devised a commercial refrigeration machine to remove the humidity that was gumming up pages at the East Williamsburg Printing section of Brooklyn [2]. The practice of using air conditioning was slowly adopted in residential buildings and commercial space in the early 1920s. The concept of thermal comfort during driving was influenced by the introduction of closed-body automobiles in 1908. The need for thermal comfort and safety during driving in varied climatic conditions generated the interest in mobile air conditioning.

**'Thermal comfort** is the condition of mind which expresses satisfaction with the surrounding thermal environment and is assessed by subjective evaluation'

– ASHRAE Terminology glossary

Comfort cooling systems for mobile (cars) was introduced in 1930. In the same year, C&C Kelvinator outfitted Cadillac (Figure 1) owned by John Hamman Jr. of Houston, Texas with a

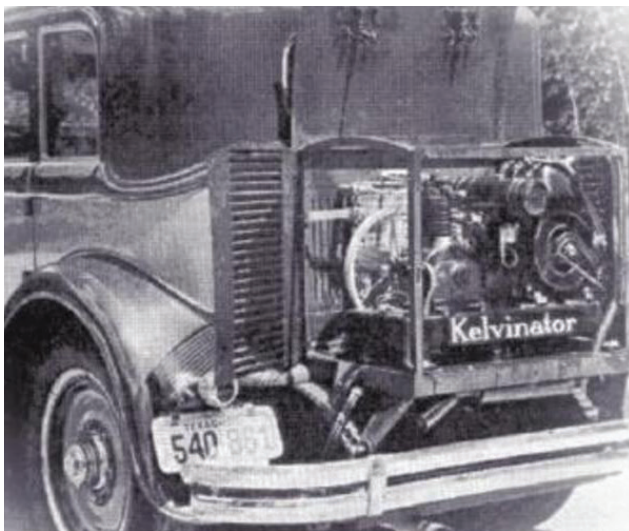

Figure 1: First air-conditioned car by C&C Kelvinator [3]

customized 0.37 kW Kelvinator refrigeration unit powered by a 1.1 kW gasoline engine [3].

The mass production of commercial air conditioned cars was outpaced between 1940 and 1942 by Packard Motor Company with 1500 units and Cadillac Division of General Motors with 300 units. By 1947, the mobile air conditioning witnessed an unprecedented growth with independent private players installing the system in all makes of cars. The most salient system with all-season air conditioning was offered by Nash Ambassador in collaboration with select group of carmakers in 1954. The compact design and its competitive cost (USD 395) made the Nash MAC design (Figure 2) a standout amongst other players. In the decade of 1960s, the demand for pre-installed air conditioning system in the passenger cars and buses soared, marking it as a standard accessory in all the models of expensive cars.

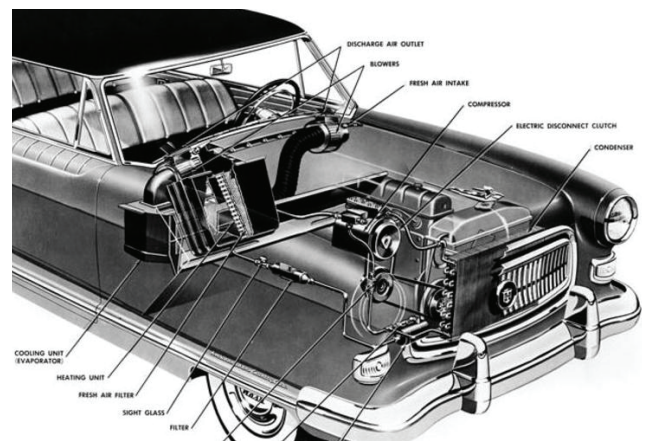

Figure 2: The 1954 Nash All-Weather Eye automotive air-conditioning system with single knob control [3]

The roots of mobile air conditioning, a more advanced control optimization and compactness, can be traced to the first comfort cooling system installed in the 1940 Packard model. Mobile air conditioning has now become an integral part of vehicles of all categories, providing optimum thermal comfort while driving in varied climate conditions.

# LANDSCAPE OF INDIA'S MOBILE AIR CONDITIONING

India, the fifth largest economy in the world, harboring approximately 1.32 billion people, has been playing a leading role in the global automobile sector. The sector is widely regarded as 'sun rise sector' for reshaping the country's industrial development and economic growth. According to the Society of Indian Automobile Manufacturers (SIAM) Annual Report 2018-19, the automobile industry contributes 7% of the country's GDP and provides employment opportunities to 8 million (direct jobs) and 29 million (indirect jobs) people. The Indian automobile sector also holds a number of feathers in its cap, namely world's largest two-wheeler maker[4], second largest heavy bus maker, third largest heavy truck manager, and fourth largest car maker[5]. During the same reporting year 2018–19, the sector produced 30.9 million vehicles as against 29.1 million during 2017–18, registering a growth of 6.26% over the same period [5]. About 85% of the total production is engrossed for domestic sales (26.29 million units) and the remaining 15% is exported (4.63 million units). The passenger vehicles registered a progressive growth of 3.4 million units during the same reporting year. The country's sectorial categorization is depicted in Figure 3.

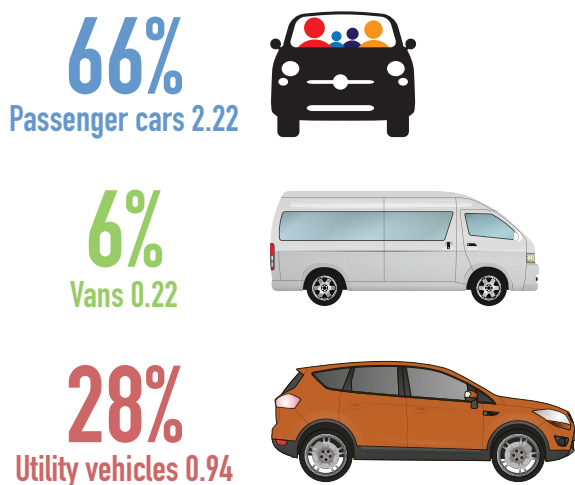

Figure 3: Domestic sales of passenger vehicles - 2018-19 (in millions) [5]

Backpedaling to the pre-independence era, India's first indigenous car industry was launched in the 1940s with the establishment of Hindustan Motors and Premier Automobiles Limited. Till 1980, the automobile production was controlled by the government, creating a waiting list for all products. The phenomenal transition of Indian automobile sector happened in 1982 with the establishment of Maruti Udyog Limited (MUL), a joint venture between the Government of India and the Suzuki Motor Corporation as minor partner, to manufacturing fuel-efficient cars that catered the middle income group of the country [6]. The sector's growth further steered with the incorporation of 1991 Economic Liberalization Policy and the New Automobile Policy in 1993, which facilitated the entry of global automakers to India [7]. In the last three decades, the sector has witnessed an impressive growth due to numerous factors, viz. (i) domestic demand; (ii) Foreign Direct Investment (FDI) impact; (iii) collaboration and Joint Venture (JV); (iv) government policies; (v) technology development; (vi) progression of indigenous companies. The Indian automobile sector is constantly experimenting to produce comfort and aesthetic vehicles at the possible affordable cost. With the implementation of BSVI- (Bharat Stage) emission norms, wef. April 2020 and offset crash regulation last year, all passenger vehicles being manufactured in India are at par with Europe.

## MOBILE AIR CONDITIONING – AN OVERVIEW

The fuel economy 'mileage' is the most important consideration for consumers in India while purchasing a vehicle. The vehicle's mileage is influenced by its technology, design, engine capacity, air-conditioning system, driving conducts, etc. The air conditioning system is widely regarded as a single largest auxiliary load in an automobile. In 2007, a research study conducted by The Energy and Resources Institute (TERI) and National Renewable Energy Laboratory (NREL) showed that the air conditioning system in a car is responsible





for 19.4% of the vehicle fuel consumption in India [8]. The study also highlighted that from 2010, most of the cars produced in India are equipped with factory installed air conditioning systems. A series of environmental impact got activated with the increase in vehicle sales and capacity in the last decade. The persistent consumption of additional gasoline (petrol), diesel, and gas to power the compressor and its lifetime load whether it is ON/OFF in vehicles leaves a large carbon footprint in the atmosphere. Fueling to it, the inefficient and obsolete mobile air conditioning technology practices and high Global Warming Potential (GWP) refrigerants further propel the vehicular greenhouse gas emissions associated with excessive fuel consumption and refrigerant leakages (system leakages, accidents, losses at service and scrap). Underlining its importance and scope, the Ministry of Environment Forests and Climate Change, Gol released a comprehensive strategic document 'India Cooling Action Plan (ICAP)' in March, 2019 [9]. The plan outlays the road map that addresses the opportunities and actions for cooling sector over the next 20 years. The document includes a chapter on 'Transport air conditioning' sector, highlighting the massive growth of transport sector and its associated refrigerant demand in the coming decades. The document [10] accentuates the following key transportation stats: (i) passenger vehicle to grow 9% annually till 2040; (ii) buses to reach 4 million in 2037–38 from 2.2 million in 2017–28; (iii) refrigerant demand to reach 25,000 MT in 2037–38 from 6000 in 2017–18;. The refrigerant leakage in mobile air conditioning sector is 10–15% annually in developed countries and around 20% in developing countries [10].

## MOBILE AIR CONDITIONING – PROCESS DESCRIPTION

The MAC system (Figure 4) [11] provides controlled and comfortable environment in the passenger cabin at all climatic conditions. The system controls the cabin temperature, humidity, air circulation and

ventilation, defrost or defogging of the windshield, cleaning of air from odour, pollutants, dust, pollen, etc. The MAC system uses vapour compression cycle to cool the ambient air, where the working fluid (refrigerant) is pushed through the system and undergoes state changes (from liquid to gaseous and back). The two major types of mobile air conditioning systems used in the vehicles are (i) thermostatic expansion valve – receiver dryer (TXV-RD) (Figure 4); (ii) Orifice Tube – Accumulator Dryer (OT-AD) (Figure 5) [12]. The expansion valve controls the refrigerant flow in the TXV-RD, by monitoring the refrigerant superheat at the evaporator outlet. The OT-AD system uses a fixed diameter orifice tube to control the refrigerant flow. The basic components of the mobile air conditioning system are: (i) Compressor; (ii) Condenser; (iii) Expansion device; (iv) Evaporator; (v) Receiver dryer or accumulated dryer.

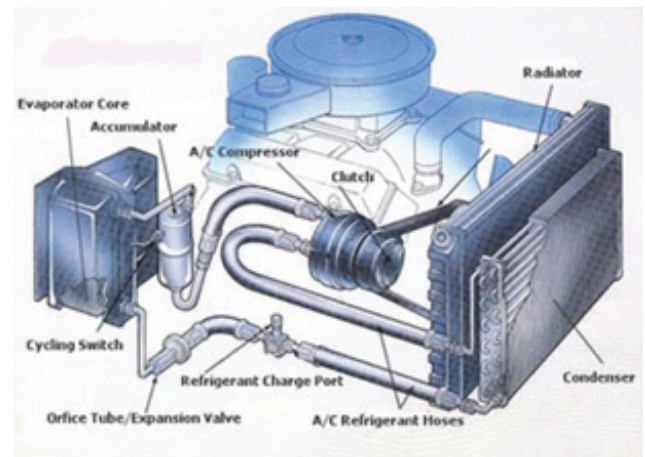

Figure 4: Schematic representation of MAC system

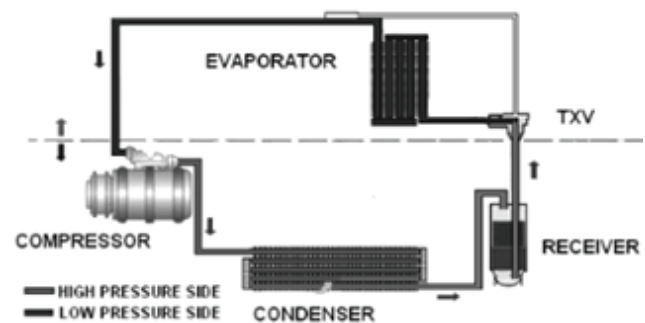

Figure 5: TXV-RD [12]

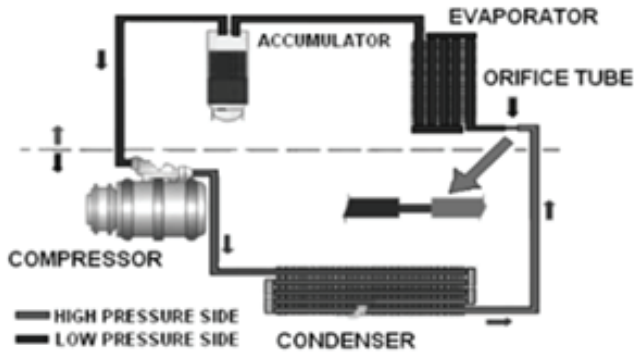

Figure 6: OT-AD[12]

Table 1: The basic components and their features of the mobile air conditioning system

Compressor	<ul style="list-style-type: none"> <li>• It compresses and pressurizes working fluid refrigerant from the evaporator outlet and delivers high-pressure and high-temperature refrigerant to the condenser</li> <li>• It is powered by a drive belt from the engine and has an electrically operated engagement clutch to turn the air conditioning (A/C) system ON or OFF</li> <li>• Major types: (i) reciprocating compressors [Fixed Displacement Compressors (FDC) and Variable Displacement Compressors (VDC)]; (ii) Scroll compressors; (iii) Rotary Compressors</li> <li>• Compressors used to weigh over 27 kg in the 1950s, which has been improved to weigh about 4–7 kg currently</li> <li>• Global market share: (i) Reciprocating compressor (about 80%); (ii) Scroll and Rotary compressor (20%)</li> </ul>	Evaporator	<ul style="list-style-type: none"> <li>• Its main function is to dehumidify and cool the ambient air going to the passenger compartment, thus reducing the sensible and latent heat from the incoming air to the evaporator.</li> <li>• The evaporator is located in the Heating, Ventilation and Air Conditioning (HVAC) module before the heater core, and the heater core is positioned at some angle with respect to the evaporator in most designs. Equal or lower amounts of airflow (than that going through the evaporator) can go through the heater so the that bi-level performance (hot air to the feet and cold air to the face) from the air conditioning system can be achieved when desired.</li> <li>• Deliver different modes of conditioned air to the passenger cabin: (i) cooling; (ii) heating; (iii) bi-level; (iv) heating/defrost, and (v) defrost/demist</li> </ul>
Condenser	<ul style="list-style-type: none"> <li>• It is a typical cross-flow heat exchanger which de-superheats, condenses the high temperature and high pressure refrigerant gas with cooler ambient air flowing on the fin side.</li> <li>• It rejects heat gained by refrigerant from the evaporator, compressor, and engine compartment lines.</li> <li>• Historical development of condenser: Tube and fin → Serpentine → Parallel flow → Parallel flow / RD [13]</li> </ul>	Receiver dryer or Accumulated dryer	<ul style="list-style-type: none"> <li>• Receiver dryer (RD) is used in the TXV system and it is located upstream of the TXV. Its specific functions are: (i) to separate the incoming refrigerant from the condenser into liquid and vapour, allow only liquid to exit; (ii) store excess liquid refrigerant to meet the high air conditioning demand; (iii) remove moisture and filter out debris from the circulating refrigerant.</li> <li>• Accumulated dryer (AD) is used in the OT system, and is located downstream of the OT. The only primary difference between AD and RD is that it separates the incoming refrigerant from the evaporator outlet into liquid and vapour, and allows only vapour to exit, which enters the compressor.</li> </ul>



# TECHNOLOGY LANDSCAPING

The compressor is considered as the heart of the MAC system, which is driven by drive belt from the engine. The research study conducted by Jungwoo Lee et al.[14] concluded that the compressor is the most important component, consuming 77–89%

of fuel utilized for cooling in a MAC system. This is followed by other components in the order of blower (6–12%), cooling fan (4–10%), and clutch (0.7–2%). The results explicitly stress that advanced and efficient compressor with periodic maintenance is required to reduce its auxiliary load and associated fuel consumptions. Shah [12] collated the comparative analysis of various compressors used in an MAC system, represented in Table 2.

Table 2: Comparative analysis of various compressors used in MAC system

Parameters	Unit	Compressor types				
		Fixed displacement compressor	VDC, internally controlled	VDC, externally controlled	Scroll compressor	Rotary compressor
Compressor displacement	cc	80–200	120–170	120–170	60–115	70–142
Compressor power at 1,800 rpm	kW	1.48–3.6	~2.8	2.2–2.8	1.71	1.6–2.85
Cooling at 1,800 rpm	kW	2.94–7.2	~6	4.9–6	2.33	3–6.4
$\eta_i$ range	%	45–70	45–70	45–75	60–80	50–70
$\eta_v$ range	%	50–69	60–74	60–74	85–95	75–85
Compressor weight	kg	4.3–7.2	~6.5	5.3–5.4	4	2.6–2.9
Major advantages	-	Simple mechanism and reliable	Better coefficient of performance (COP) and human comfort	Better COP and human comfort	Better $\eta_v$ and compact in size	Low cost, compact in size and weight
Major disadvantages	-	Lower $\eta_v$ and high noise due to frequent on-off	High cost and complex mechanism	High cost and complex mechanism	High cost, serviceability problem	Performance deteriorates at higher speeds and unsuitable for larger loads
Approximate worldwide business	%	Approximately 66% - decreasing	Approximately 14% - increasing		Approximately 12% - increasing	Approximately 8% - increasing

VDC – Variable displacement compressors,  $\eta$  – efficiency

Source: [12]

The fuel consumption associated with cooling load and the direct emissions through refrigerant leakage could be addressed with the following proposed areas:

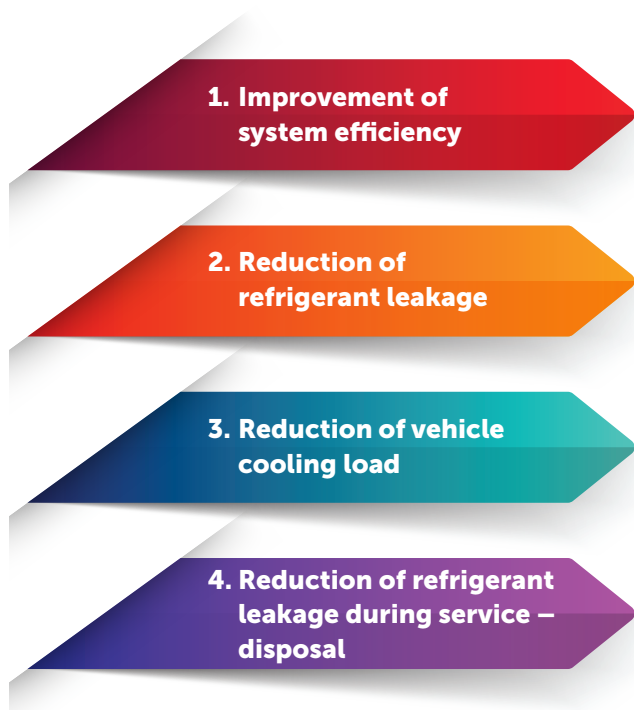

## REFRIGERANT – THE VITAL FLUID

Refrigerant is commonly termed as the blood of any HVAC systems, 'used for heat transfer in a refrigerating system, which absorbs heat at a low temperature and a low pressure of the fluid and rejects heat at a higher temperature and a higher

pressure of the fluid, usually involving changes of the state of the fluid' [15]. The invention of R12 refrigerant [Chlorofluorocarbon (CFC)/Feron] in 1928 by General Motors was the beginning of mobile air conditioning sector. The first prototype system using R12 was installed in a 1939 Cadillac. Thenceforth, the unprecedented growth of automobile sector with factory preinstalled air conditioning system steered the multi-fold growth of refrigerant usage worldwide. The massive production and usage of CFC prompted the catastrophic effects on the earth's atmosphere. This was first discussed by American Chemists Mario Molina and F. Sherwood Rowland of the University of California in 1974. They informed that the human produced CFC containing Carbon, Fluorine and Chlorine was the major cause of ozone depletion in stratosphere [16]. The historical 'Montreal Protocol (MP)' agreement, ratified by 197 parties in September, 1987, recognized the harmful effects of CFCs and other ozone depleting substances (ODS). The MP protocol aided in reducing more than 97% of all global consumption and production of controlled ODS [17]. The refrigerant transition occurred during the early 1990s with zero ODP (Ozone Depleting Potential) R134a (HFC134a) replacing the conventional R12 in developed nations and subsequently in developing nations during the 2000s. In contrast, the R134a relatively possesses higher Global Warming Potential of 1,430 aggregating the greenhouse gas emissions levels in the atmosphere and warming the earth's temperature. Over the years, several alternative refrigerants, as listed in Table 3, have been evaluated for the substitution of high GWP R134a [12].



Table 3: Alternative refrigerants for MAC system

Refrigerant	Outline	GWP	Flammability	Toxicity
R1234yf	<ul style="list-style-type: none"> <li>An unsaturated fluorinated hydrocarbon, HFO-1234yf, looked to be the best drop-in refrigerant replacing R134a</li> <li>The ODP is zero, as it does not contain any chlorine and relatively negligible GWP</li> <li>The molecular weight is slightly higher than R134a, so it requires more charge</li> <li>Mildly flammable, but significantly less than R152a and R32</li> <li>It offers equivalent or lower toxicity compared to R134a and R12</li> <li>European countries, the USA, and Japan have already switched over to R1234yf from R134a in 2014</li> <li>High upfront cost: 20x more than R134a</li> </ul>	4	2	A1
CO <sub>2</sub>	<ul style="list-style-type: none"> <li>As a refrigerant it traces history back in 1847, in the process of ice making</li> <li>Non-flammable, non-HFC natural fluid with low GWP of 1</li> <li>Eliminates the process of recycle of refrigerant</li> <li>Low cost refrigerant</li> <li>The major disadvantage of CO<sub>2</sub> refrigerant based system is it requires high operating pressures (about 6–8 times higher than R134a) resulting slightly heavy A/C system components. This subsequently results in additional fuel consumption in carrying the extra weight and higher upfront cost due to system design and component requirements.</li> </ul>	1	1	A1
R152a	<ul style="list-style-type: none"> <li>The GWP and molecular weight are low compared to R134a</li> <li>It can be used only in the engine compartment in a secondary loop system, due to its slightly higher flammability characteristics</li> <li>The major advantage is that it requires low charging due to its lower density</li> <li>The R152a-based system has better cooling performance at high loads compared to R134a.</li> <li>The system demands more leak-tight design, due to smaller molecular size</li> </ul>	124	2	A2
Fluid H	<ul style="list-style-type: none"> <li>It is a binary azeotrope of two blend refrigerants: CF<sub>3</sub>CF = CH<sub>2</sub> and CF<sub>3</sub>I.</li> <li>It possess low GWP, zero ODP, and non-flammable characteristics</li> <li>With its higher molecular weight than R134a, it requires 20% more charge</li> <li>The initial test results found it to be toxic</li> </ul>	<10	1	A3
Fluid DP1	<ul style="list-style-type: none"> <li>It is a two component nonflammable blend refrigerant with zero ODP and low GWP</li> <li>The refrigerant requires slight (10%) more charge compared to R134a</li> <li>It appeared to have some toxicity</li> </ul>	≈40	1	-
Fluid AC1	<ul style="list-style-type: none"> <li>It is a non-azeotropic refrigerant with zero ODP, low GWP, and nonflammable characteristics</li> <li>The initial toxicity results appeared to be promising</li> </ul>	<150	1	-

# OPPORTUNITIES FOR EFFICIENT MAC OPERATION

The understanding of heat load range helps in identifying the opportunities for reduction in fuel consumption associated with air conditioning system of vehicles [12].

- Solar insolation through windows and glass in the passenger compartment: 26–44%
- Exterior metal surface: 12–18%
- Floor: 6–11%
- Occupants: 16–27%
- Cold air leakage for intake of fresh air: 9–17%
- Load from blower: 4–7%

India Cooling Action Plan emphasizes on improving the MAC system efficiency; implementation of a fuel-efficient MAC system and reducing refrigerant demand through design improvement and better operational efficiency would be the key aspect for the transport sector. There has been numerous research studies and experiments carried out in optimizing the compressor efficiency, cooling efficiency of condenser, heat exchanger performance, insulation, and environment friendly refrigerant transition. Detailed consolidation of compressors types explicating its technical parameters and advantages have been presented in Table 2. Based on stakeholder consultations with experts, the automotive sector has substantial scope to improve the MAC system efficiency and thereby fuel efficiency and reduction in refrigerant use. The key opportunities in Indian context are as under:

- The provision for optimum space for air flow in front of the condenser enhances the performances of the MAC system. The use of efficient insulation materials of light bulk density characteristics and reflective paints are anticipated to reduce the heat load of the vehicles.
- On the refrigerant front, the MAC system is greatly dominated by R134a refrigerant due to its low cost and availability. The refrigerants such as

R1234yf, R152a, and CO<sub>2</sub> with low environmental impacts are proposed as potential replacements for R134a possessing a GWP of 1430. Typically, about 0.4 to 1 kg of refrigerant is charged for vehicles depending upon its capacity. The refrigerant charge can be marginally reduced with the optimization of MAC system pipelines with reduced number of bends and increased suction diameter.

- Since the vehicles are prone to continuous movement and vibration, the stern design and optimization of pipelines, valves, and joints will support in alleviating the significant fugitive leakage of refrigerants.
- The challenges of safety concerns in using the slightly flammable refrigerants possessing low GWP (R152a and/or R1234yf) could be overcome with the Secondary Loop Mobile Air Conditioning (SL-MAC) system. The SL-MAC system uses energy to cool the refrigerant, which in turn cools the water or antifreeze coolant, and finally the coolant is used to cool the air passing to the cabin compartment [18]. The SL-MAC system requires comparatively low refrigerant charge to the conventional R123a refrigerant system, leading to mitigation of lifecycle refrigerant emissions. With its compact design, the SL-MAC system ensures limited hoses and pipelines, less refrigerant charge resulting in low maintenance and repairing costs. The SL-MAC system is expected to be adopted dynamically in the coming years, especially in the hybrid electric vehicles (HEV) and electric vehicles (EV).

Sectorial experts underline that there is significant refrigerant emissions occurring at the service sector end, owing to lack of awareness and unskilled technicians. The practice in handling the refrigerant disposal, particularly at unorganized service centres, without proper vacuuming and cleaning, leads to exposing the refrigerant directly into the atmosphere. Similarly, the inappropriate service practice of refrigerant pop-up leads to addition of moisture, air, and other particulates into the system. This results in inefficient operation of the MAC system, increasing the compressor load, and subsequently consuming more energy



(fuel). The moisture particulates might corrode and crumble the system components. Though the fuel consumption of passenger cars is one of the important performance parameters in the purchase decision by the customer, the power consumption by air conditioning system has not been optimized. There are no clear figures to indicate the actual fuel consumption by the air conditioning system. There is scope to improve the efficiency of the air conditioning system for the given cooling load. Reducing the heat load on the air conditioning system by improving the insulation to reduce heat ingress into the passenger cabin, reduce the loss of energy by better sealing and improving the compressor efficiency and the blower efficiency. Under the Montreal protocol commitments, the transport sector in India leapfrogged to HFCs during the CFC phase-out schedules. Transition in this sector would be a key to achieve the Kigali Amendment targets as the demand for HFCs is growing in India and as per ICAP, the automobile sector contributes around one-third of the total demand.

## DISCUSSIONS AND WAYS FORWARD

Making mobile cooling climate friendly is a big challenge due to technical constraints related to energy use and refrigerant safety. Improvements in system efficiency, switching to low GWP environmental friendly refrigerants and leakage free technologies, greater push for public transport infrastructure along with skilled servicing workforce and operational behavioral change would pave the way for achieving ICAP targets.

- About 20% of fuel consumed in vehicles is utilized in the mobile air conditioning system for providing thermal comfort while driving. Compressors consume about 77–89% of energy supplied to the MAC system. The deployment of VDC and optimum pipeline/hose design with minimal bends, joints will support in achieving low fuel consumption. However, due to its high upfront cost, the small car segment still continues to use the conventional compressor.
- R1234yf, R152a are considered as potential replacements for current high GWP R134a refrigerant, which is predominantly used in all the vehicles. The high upfront cost of R1234yf (approximately 10 to 15 times of R134a) is the prime factor in hindering its adoption in the Indian market conditions. Due to its slight flammability characteristics both R1234yf and R152a require additional safety design measures, which increases the overall cost. The limited availability of these refrigerants is another reason for its low penetration in India. Despite its lowest GWP value, the uptake of natural refrigerant CO<sub>2</sub> is hindered due to its high pressure operating conditions. CO<sub>2</sub> refrigerant-based systems require robust components, increasing the overall system weight and associated costs, resulting in additional fuel consumption.
- Experts have underlined that the behavioral practices in operating MAC and driving pattern influences the fuel consumption associated with its operation. Practices such as lowering the windows leads to admittance of ambient air into the cabin space and might affect the aerodynamics of vehicle and increases the air resistance, leading to excessive fuel consumption. Similarly, there is an imperative need for regulation of service centres, training and certification for personnel to handle the refrigerant charging. The unskilled technicians with inappropriate servicing practices will result in direct release of refrigerant gases to the atmosphere and reducing the overall performance of MAC systems.
- India with its recent initiative 'Faster Adoption and Manufacturing of Hybrid & Electric Vehicles in India (FAME India) Scheme' aims to promote the adoption of electric and hybrid vehicles. The scheme focuses for a market creation of 55,000 four-wheelers and 7,000 buses in the coming years. In HEV and EV, the MAC system is directly driven by the electric motor and anticipated to consume less energy. However, the battery storage unit driving the prime engine requires additional cooling for its efficient operation and thereby increases the overall cooling load of the vehicle. SL-MAC is proposed as an ideal option for HEV and EV.

- In India, because of its sensitive market conditions and low-cost economy preferences, a slight additional increase incurred in the technology upgradation or refrigerant transition will severely affect the sales of vehicles. This primarily drives the auto-companies to employ affordable technology and refrigerant practices over the environment commitments. Innovative market mechanisms and/or financial schemes (subsidy/incentives) are looked for in transforming the mobile air conditioning sector with the best energy-efficient options and environmentally friendly refrigerants.
- A series of comprehensive studies are proposed to ascertain the gaps and comprehend

the sectorial representation pertaining to technology status and refrigerant practices in other transportation segments, viz. commercial vehicles, railways, ships, and aircrafts.

- Identification of short-, mid- and long-term strategies in improvising the technology practices, reducing the cooling demand and refrigerant transitions are endorsed to alleviate both direct and indirect emissions.
- Evolve performance standards for comparing the performance of different air conditioning systems enables us to understand the best available technology practices and opportunities for further refinements.





## REFERENCES

- [1] "Kigali Amendment implementation begins." [Online]. Available: <https://ozone.unep.org/kigali-amendment-implementation-begins>.
- [2] Penelope Green, "Do Americans Need Air-Conditioning?," *The New York Times*, 2019.
- [3] M. S. Bhatti, "Riding in comfort, Part II: Evolution of automotive air conditioning," *ASHRAE J.*, vol. 41, no. 9, pp. 44–48, 1999.
- [4] "Global two-wheeler market to grow to 62.6 million by 2025: Report," *ET Auto.com*, 03-Apr-2020.
- [5] "SIAM Society of Indian Automobile Manufacturers ANNUAL REPORT 2018-19," New Delhi.
- [6] S. Miglani, "The Growth of the Indian Automobile Industry: Analysis of the Roles of Government Policy and Other Enabling Factors," *Innov. Econ. Dev. Intellect. Prop. India China K. Liu Uday S. Racherla Ed. Comp. Six Econ. Sect.*, pp. 439–466, 2019, doi: 10.1007/978-981-13-8102-7\_20.
- [7] S. Miglani, "The Growth of the Indian Automobile Industry: Analysis of the Roles of Government Policy and Other Enabling Factors," *Innov. Econ. Dev. Intellect. Prop. India China K. Liu Uday S. Racherla Ed. Comp. Six Econ. Sect.*, pp. 439–466, 2019, doi: 10.1007/978-981-13-8102-7\_20.
- [8] L. Chaney, K. Thundiyil, S. Andersen, S. Chidambaram, and Y. P. Abbi, "Fuel savings and emission reductions from next-generation mobile air conditioning technology in India," *VTMS 8 - Veh. Therm. Manag. Syst. Conf. Exhib.*, pp. 611–621, 2007.
- [9] "Government releases India Cooling Action Plan," *Business Standard*, New Delhi, 08-Mar-2019.
- [10] "India Cooling Action Plan," New Delhi, 2019.
- [11] "Refrigerant Trends in Mobile Air-Conditioning," 2017.
- [12] R. K. Shah, "Automotive air-conditioning systems-historical developments, the state of technology, and future trends," *Heat Transf. Eng.*, vol. 30, no. 9, pp. 720–735, 2009, doi: 10.1080/01457630802678193.
- [13] A. S. Ravikumar, N. Karwall, and R. K. Shah, "Recent developments in automotive condensers and receiver-dryer technology," *SAE Tech. Pap.*, p. 10, 2005, doi: 10.4271/2005-01-1770.
- [14] J. Lee, J. Kim, J. Park, and C. Bae, "Effect of the air-conditioning system on the fuel economy in a gasoline engine vehicle," *Proc. Inst. Mech. Eng. Part D J. Automob. Eng.*, vol. 227, no. 1, pp. 66–77, 2013, doi: 10.1177/0954407012455973.
- [15] "ASHRAE terminology," *ASHRAE*. [Online]. Available: [https://xp20.ashrae.org/terminology/index.php?page\\_num=2&next=next&current\\_search=refrigerant&type\\_search=term](https://xp20.ashrae.org/terminology/index.php?page_num=2&next=next&current_search=refrigerant&type_search=term).
- [16] D. Wuebbles, "Ozone depletion atmospheric phenomenon." [Online]. Available: <http://citeseerx.ist.psu.edu/viewdoc/download?doi=10.1.1.629.6779&rep=rep1&type=pdf>.
- [17] "Ozone Layer Depletion." [Online]. Available: <https://www.thegef.org/topics/ozone-layer-depletion>.
- [18] A. James, S. O. Andersen, and J. A. Baker, "The new business case for secondary loop mobile A/C system (SL-MACs)," vol. 67, no. December, 2014.

## Notes

---

---

---

---

---

---

---

---

---

---

---

---

---

---

---

---

---

---

---

---

---

---

---

---

---

---

---

---



## Notes

---

---

---

---

---

---

---

---

---

---

---

---

---

---

---

---

---

---

---

---

---

---

---

---

---

## ABOUT TERI

The Energy and Resources Institute (TERI) is an independent, non-profit organization, with capabilities in research, policy, consultancy and implementation. TERI has multi-disciplinary expertise in the areas of energy, environment, climate change, resources, and sustainability.

With the vision of creating innovative solutions for a sustainable future, TERI's mission is to usher in transitions to a cleaner and more sustainable future through the conservation and efficient use of the Earth's resources and develop innovative ways of minimizing waste and reusing resources.

TERI's work across sectors is focused on:

- Promoting efficient use of resources across sectors
- Increasing access and uptake of sustainable practices
- Reducing the adverse impact on environment and climate

TERI works with a diverse range of stakeholders across governments, both at the national and state levels, international agencies, and civil society organizations to help deliver research-based transformative solutions. Headquartered in New Delhi, TERI has regional centres and campuses in Bengaluru, Gurugram, Guwahati, Mumbai, Nainital, and Panaji.

Currently, TERI's work is structured around seven sectors:

- Agriculture
- Climate
- Energy
- Environment
- Habitat
- Health and Nutrition
- Resources

TERI brings out Discussion Papers on key contemporary issues in sectors such as energy, agriculture, water and environment with multi-disciplinary and multi-sectoral implications for use by policy makers, legislators, researchers and practitioners. This Policy Brief has been brought out by the Earth Sciences and Climate Change Division as a part of TERI's work on refrigerant transition and cooling sector.

For more information, please visit: <http://www.teriin.org/>



Manjeet Singh, Associate Fellow,  
The Energy and Resources Institute (TERI)  
Darbari Seth Block, IHC Complex, Lodhi Road,  
New Delhi- 110003

Tel: 71102100 or 24682100  
Fax: 24682144 or 24682145  
Web: [www.teriin.org](http://www.teriin.org)  
E-mail: [pmc@teri.res.in](mailto:pmc@teri.res.in)